

Table Stand for the Rigid Heddle Loom and the Tapestry Loom (SL 2304)



Contents:

- 2 - Table Stand Uprights with Raddle/Bobbin Clamps
- Hardware: 2 - 2 1/2" trusshead machine screws
- 2 - 2 1/2" flathead machine screws
- 2 - 1/4" washers
- 2 - 1/4" wing nuts

You will find two different types of 2 1/2" machine screws enclosed. The flathead screws are used to attach the stand to the Rigid Heddle Loom, and the trusshead machine screws are used to attach the stand to the Tapestry Loom.

The Table Stand is designed to mount the Rigid Heddle Loom or the Tapestry Loom onto a table top. The two sides of the stand are attached first to the loom, and then the stand and the loom are attached to a table.

1. To attach the Rigid Heddle Loom to the Table Stand

Push a 2 1/2" flathead machine screw through the hole in the heddle holder on the inside of the loom, and then through the hole in the top of the Table Stand upright. Secure with a washer and a wing nut. Repeat for the other side.

For weaving you will attach the loom to the table with the front of the loom extending out from the edge of the table (Figure 1A). When you are threading the loom, however, you may want to attach the loom with the back of the loom extending from the edge of the table. In this case you will need to re-install the brackets on the opposite sides of the loom (Figure 1B).

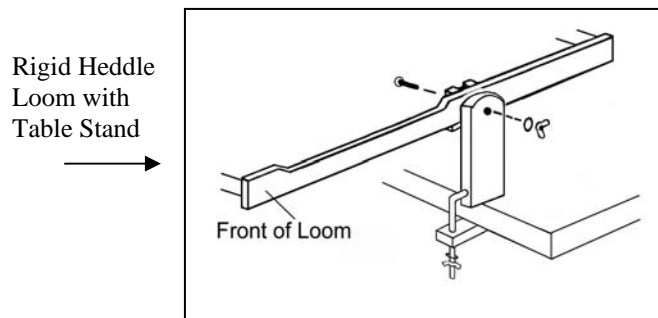

Figure 1A

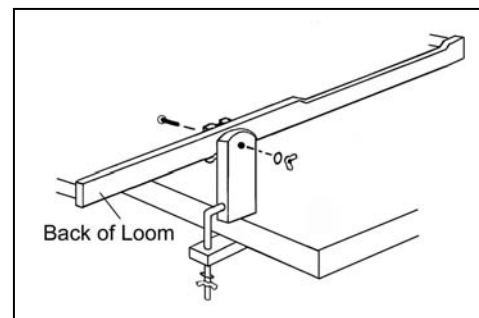
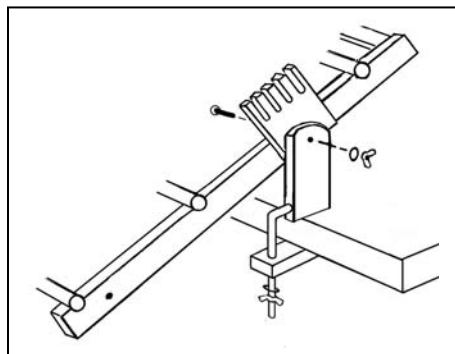

Figure 1B



2. To attach the Tapestry Loom to the Table Stand

Push a 2 1/2" trusshead machine screw through the hole in the heddle holder on the inside of the loom, and then through the hole in the top of the Table Stand upright. Secure with a washer and a wing nut. Repeat for the other side.

Tapestry Loom
with Table Stand