

# VERTICAL WARPING MILL

## ASSEMBLY INSTRUCTIONS



Find out more at [schachtspindle.com](http://schachtspindle.com)  
Schacht Spindle Company 6101 Ben Place Boulder, CO 80301  
p. 303.442.3212 f. 303.447.9273

# VERTICAL WARPING MILL

## ASSEMBLY INSTRUCTIONS

### PARTS

- 4 – frame cross slats
- 4 – frame cross slat supports
- 2 – warping peg holders with pegs
- 2 – warping peg holder supports
- 2 – corner blocks
- 1 – base top
- 1 – base bottom

### TOOLS

- Phillips screwdriver
- Flat screwdriver
- Pliers
- Adjustable wrench

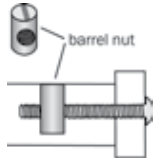

### HARDWARE

- 8 – 1-3/4" machine screws
- 8 – barrel nuts
- 1 – axle
- 4 – 1-3/4" wood screws
- 4 – 1/2" washer
- 1 – 8-coil spring
- 1 – 1/2" lock nut
- 4 – rubber bumpers
- 4 – 3/4" wood screws
- 4 – 1/4" washer
- 4 – wing nuts
- 4 – carriage screws
- 1 – 1" wood screw
- 1 – 1/2" regular nut

### ASSEMBLE THE WARPING PEGS

Attach a warping peg holder to each warping peg holder support, using 2 carriage screws, 2 wing nuts and 2 washers on each assembly (figure 1). Insert each bolt from the peg side through the holder and the support and fasten with a washer and wing nut.

### ASSEMBLE THE FRAMES

1. Assemble one frame completely. Orient the frame sides with the countersunk holes to the outside. Place 1-3/4" machine screws in the countersunk holes and secure with barrel nuts (figure 2). Make sure the notches in the center of the cross pieces face in the same direction.

2. Assemble three of the four corners of the second frame, and then interlock this second frame with the first frame. The notches on the first and second frames should face each other so that the two frames will fit together (figure 2). Now fasten the remaining corner of the second frame.

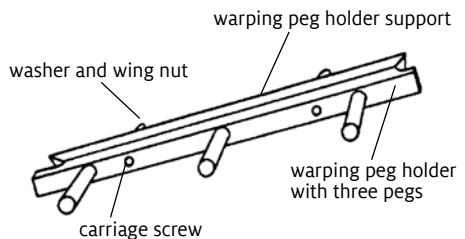

FIGURE 1

## ASSEMBLE THE WARPING MILL BASE

1. Insert the unthreaded end of the steel axle into the base top, carefully aligning the hole in the axle with the countersunk hole in the base. If you have trouble adjusting the axle, locate the 1/2" nut in the hardware bag. Be sure it is not the locking 1/2" nut that has plastic inside and is thinner. Thread this nut onto the threaded end of the axle, then use a wrench to grip the nut and turn the axle so that the hole in the base lines up with the hole in the axle. Thread the #10 Phillips head screw into the countersunk hole and tighten this screw so that the head is flush or just below the surface of the wood. Now remove the 1/2" nut; it will not be used in the rest of the assembly.

2. Place the base top over the base bottom and secure with the two corner blocks. Place them opposite each other and secure with four 1-3/4" long wood screws (the large hole in the center of the corner block is not used). Work on a level surface so as to assemble the base squarely.

3. Attach the four rubber bumpers to the bottoms of the base top and base bottom with the 3/4" wood screws. By tightening and/or loosening the screws that hold the bumpers, you can level the legs as needed.

4. Place two steel washers over the axle and let them rest on the top of the base.

5. Slide both frames over the axle. If the frames do not slide over the axle easily, slightly loosen all eight 1-3/4" machine screws on the frames. Retighten when the frames are in place.

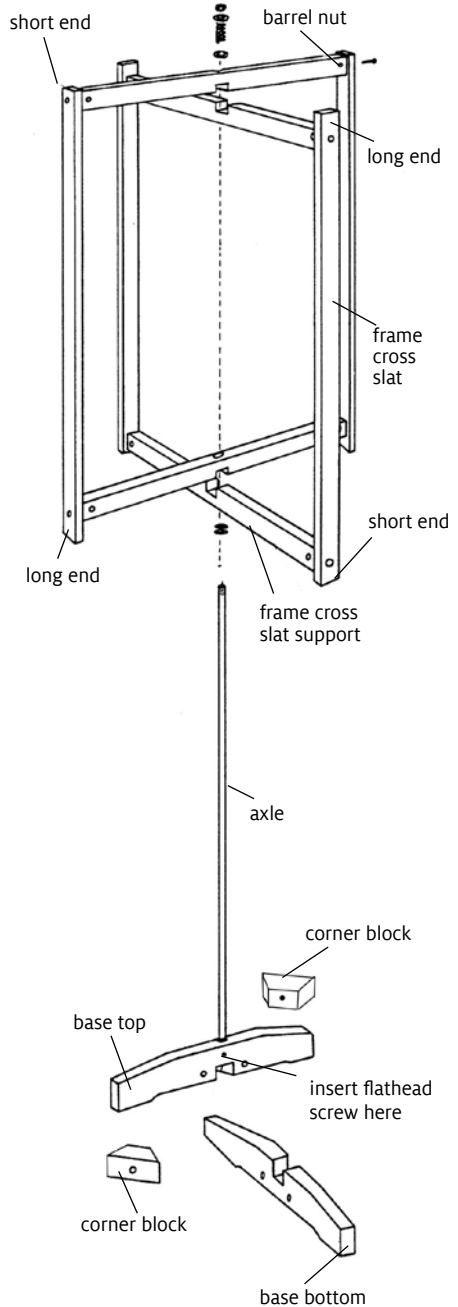

FIGURE 2

6. Place a steel washer, the spring, a washer, and then the lock nut on the axle. Tighten the lock nut enough to compress the spring slightly so that the end of the axle and lock nut are flush.

### **ATTACH THE WARPING PEGS**

Attach the warping peg holder to the frame cross slats by tightening the 2-1/2" carriage bolts and wing nuts, with washers. The two sets of peg holders may be attached to any side of the warping mill.

### **WIND A WARP**

Cut a guide string the length of your warp plus a few inches. Use a yarn or string that is visibly different from your warp yarn.

Attach the guide string at one warping peg holder. Make the first leg of the cross, then turn the warping mill to wind the guide string around it. Space the windings of the guide string to allow room for multiple warp ends. Adjust the second warping peg holder so that you can attach the guide string to a peg.

Begin winding your warp by attaching your yarn to the first warping peg holder. Make the cross, then turn the mill with one hand while following the guide string with the other hand holding the warp yarn, until you reach the second warping peg holder.

Loop your warp yarn around the peg you chose on the second warping peg holder. Reverse the direction you turn the warping mill, follow the guide string back to the first warping peg holder, and complete the cross.

### **REMOVE THE WARP**

To remove the warp from the warping mill, loosen the wing nuts on one set of the peg holders and slide this set of pegs a few inches towards the other set of pegs. This will relieve enough tension to remove the warp easily.

### **FOLD THE WARPING MILL**

To fold the warping mill, remove the warping peg holders and gently pull the frames apart enough to separate the notches and swivel the frames flat.

