

WOLF LOOM DOUBLE BACK BEAM

ASSEMBLY INSTRUCTIONS



Find out more at schachtspindle.com

Schacht Spindle Company 6101 Ben Place Boulder, CO 80301

p. 303.442.3212 f. 303.447.9273

© 2011 Schacht Spindle Company, Inc.

09.11

DOUBLE BACK BEAM FOR WOLF LOOMS

PARTS

- 2 – Baby or Mighty Wolf apron rods
- 2 – Baby or Mighty Wolf lease sticks
- 1 – Wolf Double Back Beam Support - Left (with insert installed)
- 1 – Wolf Double Back Beam Support - Right
(with insert, carriage bolt with washer and lock nut, roll pin, and long barrel nut installed)
- 1 – BW Rear Oval Beam, or MW Rear Oval Beam
- 1 – Baby or Mighty Wolf Warp Beam (with brake hub and axles installed)

- 1 – Wolf Double Beam Wooden Brake Handle with Tab Assembly
- 1 – Wolf Warp Crank Bar with Tapered Handle and hardware
- 1 – 61" Brake Cable Cord
- 5 – BW Apron Cords, or 7 - MW Apron Cords (42" long)
- 2 – Black Threaded Knobs (2-1/4")
- 1 – Wolf Brake Bar (w/attached brake cable)
- 2 – Wolf Double Beam Metal Fold-up Supports

HARDWARE

- 2 – 5/16" x 2" Carriage Bolts
- 1 – 1/8" x 1-3/16" Eye Screw
- 5 – 1/4" Nylon Washers
- 1 – 5/16" Regular Hex Nuts
- 2 – 3/16" x 1-1/4" Carriage Bolts
- 5 – 3/16" Washers
- 2 – 3/16" Lock Nuts
- 1 – 1/4" x 2" Truss Head Machine Screw
- 2 – 1/4" Barrel Nut
- 6 – 1/4" Washers
- 2 – 5/16" Locking Hex Nuts
- 1 – Slim 5/16" Locking Hex Nut
- 2 – 3/8" Washers
- 1 – 3/8" Washer (with larger outside diameter)
- 2 – 1/4" x 1" Fender Washers
- 1 – Wolf Brake Cap Nut
- 1 – Wolf Brake Spring (w/attached insert)
- 1 – Wolf Brake Plastic Peg
- 1 – 1" S-Hook
- 1 – 1/4" Lock Nut
- 1 – Wolf Brake Bar Eye Bolt
- 2 – 1/4" x 1-1/4" Trusshead Machine Screws

INSTRUCTIONS FOR DRILLING HOLES FOR DOUBLE BACK BEAM FOR OLDER WOLF LOOMS

Before starting to install your double back beam, find your serial number on the upper right castle side or under the harnesses on the cross-brace. It is most important that you mark and drill these holes accurately to insure that your loom will work its best. You will need 1/8", 3/16", 1/4" and 5/16" drill bits. Refer to figure 1 on the next page.

If your serial number starts with a 4- or an 8- or has a serial number earlier than 100189-1 (the first six digits of the serial are the date, for example, 10/01/89), you will have to drill a few additional holes in the legs of your loom. Start with step one on this page.

If your serial number is 100189-1 through 021090-1, go to step three on this page. If you find that holes (L) and (P) have already been drilled, go to the Assembly Instructions on page 4.

If your serial number is 020790-1 or later, go to the Assembly Instructions on page 4.

- 1.** Drill 5/16" holes at (A) on both rear legs of the loom. Locate these holes in the center of the legs and 30-7/8" down from the top edge of the leg.
- 2.** Drill 3/16" holes at (C) on both legs of the loom. Locate these holes in the center of the legs and 3" from the edge (D). *If your serial number is earlier than 4-2287 or 8-742, this hole should be 2-7/8" from the top of the oval beam.*
- 3.** Drill a 1/4" hole (L) through the right front leg, 4-1/2" from the top edge of the leg, and centered on the leg.
- 4.** Drill a 1/8" hole (P) 5/8" deep centered in the right rear leg, 32-7/8" from the top edge of the leg.

ATTACH THE DOUBLE BACK BEAM SUPPORTS FIGURES 1 AND 2

1. Insert the 3/16" x 1-1/4" carriage bolts through the square holes in the metal fold-up bars. Place a 3/16" washer on the carriage bolt and then place the bolt through the hole in the loom legs at (C) from the outside to the inside of the leg so that the bar hangs straight down behind the loom's warp beam. Install a washer and 3/16" lock nut on the carriage bolt at the inside of the leg and tighten it so that the metal supports just pivot freely.
2. Attach the double back beam supports to the inside of the rear loom legs as follows: align the left and right supports with the cutout for the rear oval beam at the top and inside of the each support. Insert

the 5/16" x 2" carriage bolts through the holes in the loom legs at (A) from the outside to the inside. Place the double back beam supports on the screws and fasten with a 1/4" washer and a regular 5/16" (not locking) hex nut. Tighten the nut drawing the head of the carriage bolt all the way into the wood. Now, remove the regular hex nut you have just tightened and install a locking 5/16" hex nut in its place. Tighten the lock nut just enough to allow the double back beam supports to pivot freely, but not loosely.

3. Insert the 1/4" x 1-1/4" trusshead machine screws through the round hole in the fold-up bars and screw them into the insert on the inside of the double back beam supports at (F) in figure 1.

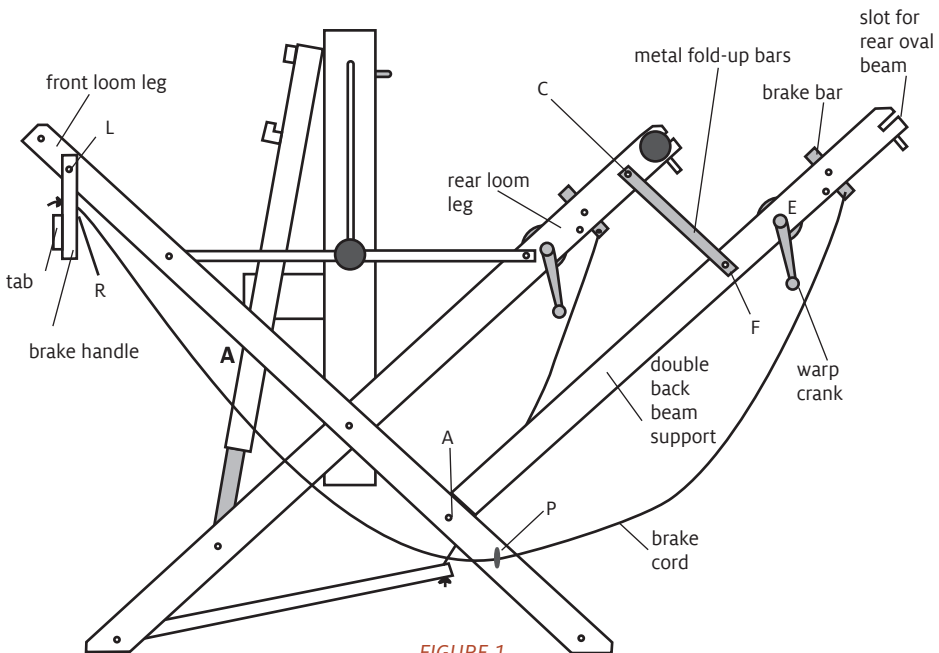

FIGURE 1

ASSEMBLE THE BRAKE RELEASE SYSTEM (FIGURE 1)

4. Attach the brake handle to the outside of the right front leg at (L). Insert a 1/4" x 2" trusshead machine screw into the handle. Slide three 1/4" nylon washers onto the screw and put the screw through the leg using a 1/4" washer and lock nut to secure.
5. When you pull the brake handle up to release the friction brake, pivot the tab over to hold it in the release position while you are either winding on a warp or winding your fabric onto the cloth beam.

6. Attach the S-hook to one end of the brake cord: Insert one end of the cord through the closed loop of the S-hook, then thread the long end of the cord through the 2nd hole from the end of the short end of the cord, and pull tight.
7. Screw the eye screw into hole (P) in the right front leg. Thread the free end of the cord through the eye screw, then up through the hole (R) in the brake handle. Put the plastic peg through the 10th loop from the end of the brake cord to hold the cord to the handle.

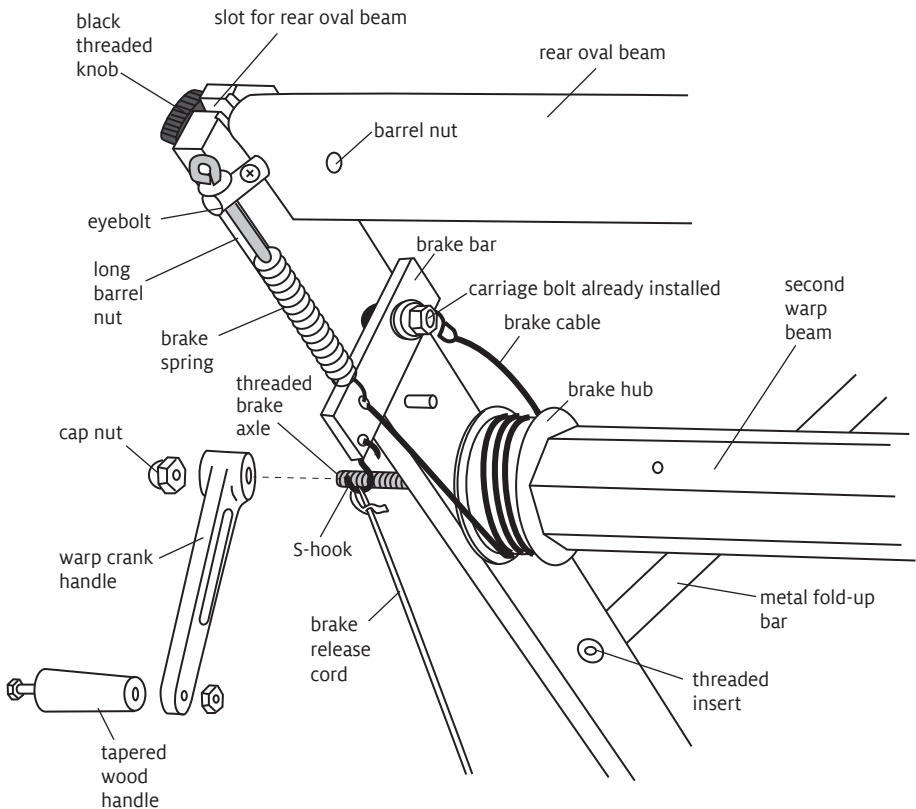

FIGURE 2

INSTALL THE SECOND WARP BEAM, BRAKE CABLE AND APRON BARS (FIGURES 1-3)

8. Place a regular 3/8" washer over each axle on the second warp beam. Insert the threaded brake axle into the hole E in figure 1. You will need to spread the double back beam supports slightly to fit both axles in place. Place the larger diameter 3/8" washer over the threaded brake axle on the outside of the double back beam support. Place the warp crank handle over the threaded brake axle with the wood handle pointing away from the loom. Secure it with the cap nut (diagram 2). Use the crank as a wrench to tighten the cap nut.

9. Place the rear oval beam in the slots in the top of the double back beam supports. Place the 1/4" x 1" fender washer on the 2-1/4" black knobs. Attach the beam with the black knobs and barrel nuts.

10. Locate the carriage bolt that is already installed in the right double back beam support just below the oval beam. Install the friction brake cable and brake bar for the second back beam as follows: Place the brake bar with attached cable over the bolt. Place a 1/4" washer over the bolt. Wrap the cable counterclock-

wise around the brake hub four times (from the outside of the loom to the inside and from under to over). Place the cable loop over the bolt followed by another 1/4" washer. Put a slim lock nut on the bolt and tighten, making sure the brake bar can still pivot freely.

11. Insert the loop of the brake spring into the brake bar in the same hole as the brake cable is attached. Place a 3/16" washer on the eye bolt and insert the bolt through the hole in the top of the already-installed long barrel nut and screw it into the insert in the brake spring. Tighten the eye bolt enough to prevent the warp beam from turning in a counter-clockwise direction. Attach the brake release cord to the brake bar by putting the S-hook through the remaining hole in the back of the brake bar. Adjust the tension on the brake release at the front of the loom by lengthening or shortening the cord with the plastic peg on the brake release handle.

To attach the apron cords on cherry looms, please see the instructions on page 8.

12. Attach the apron cords to the second back beam. There is one cord for each hole in the warp beam. Insert one end of a cord through a hole in the beam and

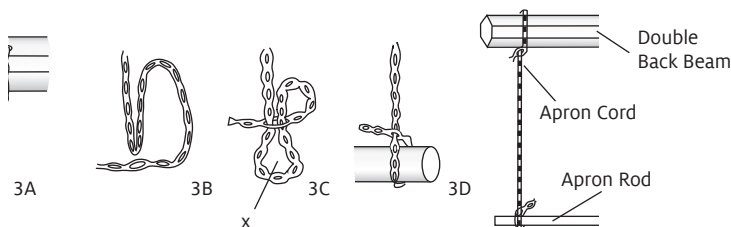

FIGURE 3

pull the cord through, a few inches. Insert the long end of the cord through the second loop of the short end that you just put through the beam and pull firmly to tighten (Figure 3A). Repeat to install all the cords.

13. Attach one of the apron bars to the apron cords, starting with an outside cord. Fold the loose end of the cord 4" from the end and insert this loop through the second loop from the end (Figure 3B). Pull until the loop is large enough to accommodate the apron bar. Slide the apron bar through this new loop (labelled X in Figure 3C).

The extra apron bar can be used for warping methods that require an extra rod through warp loops.

Your double back beam is now ready to use. After you warp your loom, you may need to adjust each friction brake to be sure it is holding. The warp that needs to vary the most should be on the second back beam. This beam's brake is controlled by a hand lever, which provides greater control over the tension on the threads.

INSTALLING APRON BARS FOR CHERRY BABY AND MIGHTY WOLF LOOMS

These instructions replace those in steps 12-13.

PARTS

One long piece of Teksolv cord
One 1/4" dowel (27" long for Baby Wolf; 38" long for Mighty Wolf)
One apron bar

1. Fold one end of the cord approximately 2" from the end, pinch the fold tightly and insert the fold through the second loop from the end of the Teksolv cord. (Figure 3B & 3C). Place this loop around one end of the 1/4" dowel and pull tight to fasten (Figure 3D).

2. Thread the other (long) end of the cord through the outermost hole on one end of the warp beam, and pull the cord through the hole until the cord and the dowel are snug against the warp beam. Now pass the cord around the apron bar leaving about 30" of distance between the warp beam and the apron bar, then bring the cord back to the warp beam and insert it in the return direction through the beam, and loop it around the dowel. Continue to thread the cord around the apron bar and through the beam in this manner, until there are four loops for the Baby Wolf, or six loops for the Mighty Wolf on the apron bar.

3. Thread the cord into the last hole on the beam and fasten the cord to the dowel as in step 1. ■

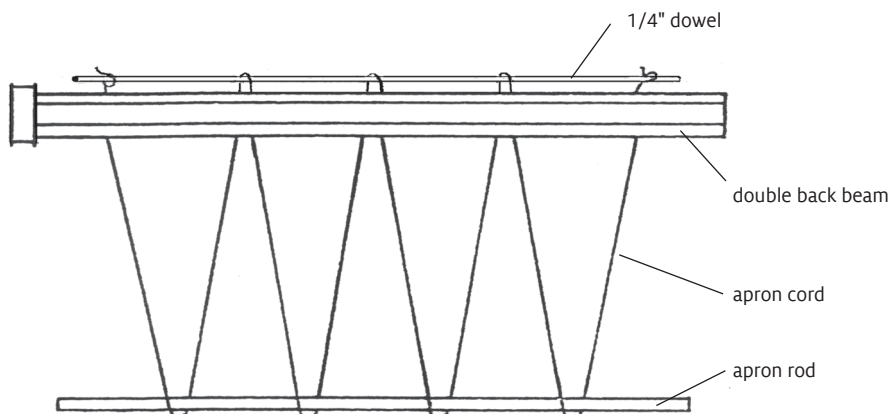

FIGURE 4