

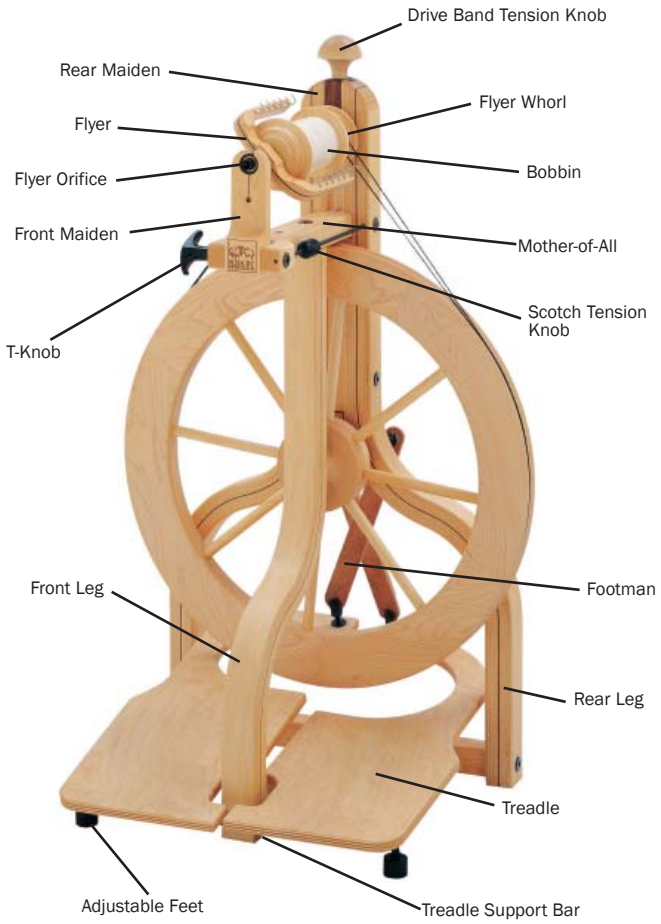

Matchless Spinning Wheel

Instructions, Maintenance and Warranty

Double Treadle Wheel



S:\Data\INSTRUCT\L Forms/warranty and maintenance/Matchless SW Cherry

Instructions and Maintenance

We are pleased that you have chosen one of our Schacht Spinning Wheels, and trust that it will give you many fruitful hours of spinning. We have taken great care in the design of our wheels to make them efficient and sturdy as well as aesthetically pleasing. Our wheels are constructed using traditional woodworking joinery, following the concept that form follows function. We feel that good design and quality craftsmanship, along with regular maintenance, ensures that your wheel will endure.

Each part has been specially designed with function in mind. During manufacturing, every part is inspected for quality, and the final assembly has been done by a skilled craftsman. Should you have any questions about the quality of the work or the materials, please do not hesitate to contact your dealer or our customer service department directly.

Your Schacht Spinning Wheel is a precision tool, having many moving parts that require regular care and maintenance. The better you understand your wheel, the more able you will be to take advantage of its many features.

Please read this booklet before you start spinning on your wheel.

Unpacking your wheel

Unpack the accessory boxes and make sure you have all the parts:

Large Box:

- 1 - Lazy Kate
- 3 - bobbins
- 3 - Lazy Kate bobbin rods
- 1 - carrying strap

in small bag:

- 1 - threading hook
- 1 - 4mm hex wrench
- 1 - 5mm hex wrench
- 3 - black retainer rings for bobbin rods
- 1 - brake tension spring and cord
- 1 - extra length of drive cord
- 10 - 1/4" trusshead screws
- 2 - 1" trusshead screws

Small box:

- 1 - bobbin
- 1 - flyer
- 1 - flyer whorl
(2nd whorl is attached to the back of the rear maiden)
- 2 - cotter pins
- 2 - treadle yoke clevis pins
- 4 - white nylon washers

Wood Parts:

- 2 - treadles with treadle yokes
- 1 - treadle support bar with attached hinges and adjuster feet
- 1 - treadle support brace

Required tools

Phillips screwdriver

Attaching the treadle support bar

Remove the leg bolt, washer and small rod from the front leg of the wheel. Remove the short rod from the bolt, and insert the leg bolt with the washer through the hole in the middle of the treadle support bar. Replace the short rod on the leg bolt, then insert the leg bolt into the hole in the front leg. Align the short rod with the slot in the front leg. Using the 4mm hex wrench, screw the leg bolt into the barrel nut glued into place in the cross brace.

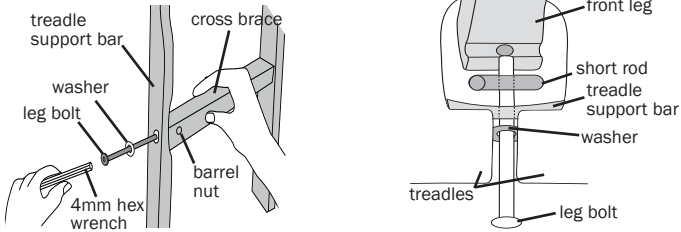

Attaching the treadles

Lay the wheel on its back on a table, tilted to either side. Use a towel or blanket to protect the table and the wheel from scratches.

Slide the left (shorter) treadle into place, allowing the treadle to hang off the edge of the table. Using a Phillips screwdriver, attach the treadle hinge to the treadle using the short screws in the small bag. Insert the screw at the far right and fasten loosely, then insert the screw at the far left. Tighten the screw only until it stops turning. Go back and tighten the first screw, then insert the remaining three screws. Be sure not to overtighten the screws. Repeat for the right treadle.

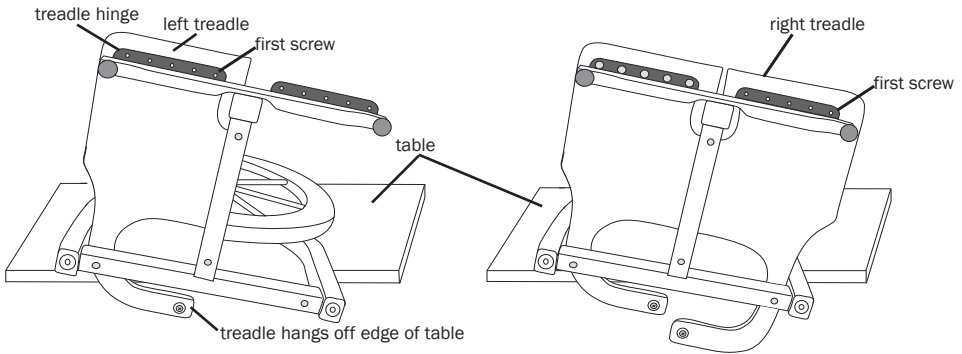

Attaching the treadle support brace

Remove the leg bolt. Place the washer and the treadle support brace onto the leg bolt, then insert the leg bolt through the treadle support bar and short rod and into the front leg. Make sure that the short rod is aligned in the slot in the front leg and that the support brace angled edge is at the top. Tighten the leg bolt only by hand. Use the 1" screws to attach the brace to the front of the treadle support bar (see diagram). Center the treadles between the back legs of the wheel. If necessary, the treadle support bar can slide a bit to the left or right to center the treadles. Tighten the leg bolt with the 4mm hex wrench.

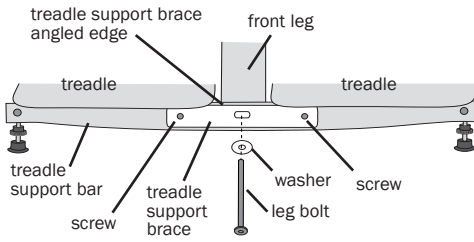

Attaching the treadle support brace

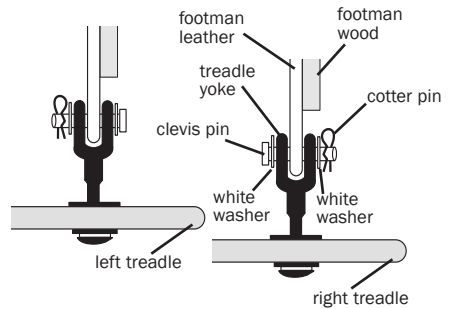

Attaching the footmen
Backs of treadles, seen from right side of wheel

Attaching the footmen

Attach the footmen to the treadles using the cotter pins, clevis pins and the white nylon washers that are packed in the small box with the flyer.

The left treadle is attached to the footman that is closest to the back of the wheel. Place the footman leather inside the treadle yoke and line up the holes. Put a washer on a clevis pin and insert the clevis pin from the front of the wheel towards the back. Put another washer on the clevis pin and secure by inserting a cotter pin through the clevis pin until the cotter pin is about halfway through the clevis pin.

The right treadle is attached in the same way, but the clevis pin should be inserted through the footman and treadle yoke from the back of the wheel toward the front.

Adjusting the treadle height

This adjustment is only necessary if your treadle is either rubbing the drive wheel or hitting the rear leg cross support. To adjust the treadle height, remove the cotter pin from the treadle-yoke pin and pull the treadle-yoke pin out of the treadle yoke. Rotate the yoke clockwise to raise the treadle and counterclockwise to lower the treadle. Make only two or three turns and reassemble the footman and treadle yoke. Repeat this adjustment until you are satisfied with the position of the treadle.

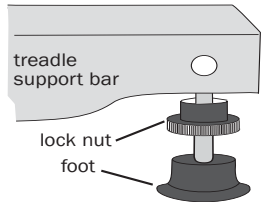

Adjusting the front legs

The front legs of your spinning wheel can be adjusted to accommodate uneven floors. Simply loosen the lock nut and screw the foot up or down as needed, then tighten the lock nut.

Installing the flyer assembly

Loosen the front maiden T-knob about one turn. Pivot the front maiden forward. Insert the flyer-bobbin-whorl assembly fitting the small end of the flyer shaft into the rear maiden bearing. Be sure to lift the drive band up and over the bobbin and whorl pulleys. Pivot the front maiden up and fit the flyer orifice into the front maiden bearing. Tighten the T-knob.

Changing bobbins

Loosen the front T-knob on the maiden about one turn. Hold the flyer with one hand and pivot the front maiden forward until the flyer orifice is out of the front maiden bearing. Hold the drive band up and out of the way as you pull the flyer towards you until the flyer shaft is out of the rear maiden bearing. Remove the flyer whorl. (Unlike most spinning wheel flyer whorls, that screw onto the flyer shaft, our quick-attach whorls need only to be pushed on and pulled off the square part of the flyer shaft.) Remove the bobbin and replace it with another one. If you are spinning in double drive mode, face the small end of the bobbin toward the flyer whorl; in Scotch tension mode, the large end of the bobbin faces the flyer whorl.

Double drive mode

We have shipped your wheel set up for double drive mode, with a medium speed flyer whorl. (The fast speed whorl is attached to the wheel behind the rear maiden.) For double drive mode, the small end of the bobbin faces the flyer. Place one loop of the drive band over the small end on the bobbin and the other loop over one of the grooves (pulleys) of the flyer whorl.

Adjust the tension on the drive band by turning the drive band tension knob (the mushroom-shaped knob on top). Start with a loose drive band. Begin to slowly treadle, tightening the tension knob until the flyer and bobbin both begin to turn. Now you can begin to spin. Turn the tension knob in a clockwise direction to increase the take-up of the yarn onto the bobbin or counter-clockwise to reduce the amount of take-up.

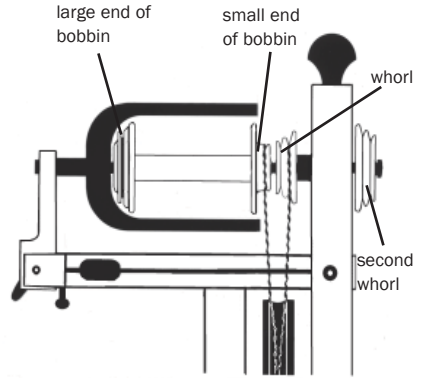

Scotch tension or flyer-lead mode

Place a bobbin on the flyer shaft with the large pulley end facing the flyer whorl. Put a flyer whorl on the flyer shaft. In Scotch tension mode, a single drive band around the drive wheel and the whorl is used. Place the band in a groove of the flyer whorl. (You can use the drive band double for this, although we recommend tying a single drive band.) The drive band should be taut but not overly tight.

Attach the Scotch tension spring to the spring bar on the left rear of the mother-of-all. Loop the cord over the large bobbin

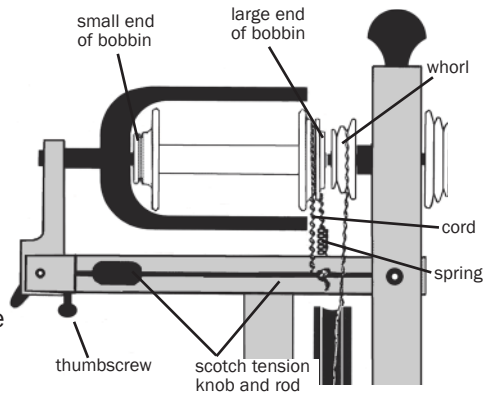

end and insert it into the front hole in the Scotch tension rod. Push about 1/2" of the cord through the hole. Loosen the thumbscrew slightly to allow the Scotch tension knob to turn. Turn the Scotch tension knob clockwise until the brake spring barely begins to stretch. Tighten the thumbscrew to secure the Scotch tension rod. Now you can start spinning. To increase the amount of take-up of your yarn onto the bobbin, turn the Scotch tension knob in the clockwise direction. To decrease the amount of take-up, turn the Scotch tension knob counter-clockwise.

When using the Scotch tension mode the yarn will wind onto the bobbin in the opposite direction than when using the double drive mode. This does not affect your spinning, but it is good to know this in case you should change spinning modes in the middle of a bobbin. If the Scotch tension rod becomes loose, you can tighten the black thumbscrew under the front of the mother-of-all.

Your drive band

Your spinning wheel comes with a pre-tied drive band (tied for double drive) and an extra length of drive band. For additional drive bands, use a soft cotton cord which is about 1/16" thick (an eight or ten-ply butcher or package twine works fine). A soft drive band allows you to use less tension than a harder, slicker cord, making treadling easier. While a soft drive band will wear quicker, we believe the gain in performance is worth more frequently changing the drive band.

Tying on a new drive band

Cut the old drive band to remove it.

For double drive mode, place a bobbin in the flyer with the small end facing the whorl. Use a medium size whorl. Adjust the drive band tension knob so that the flyer is parallel to the mother-of-all. Face the front of the wheel. Hang one end of the drive band cord over the bobbin groove so that it hangs down about 12 inches on the right side of the wheel. On the left side take the cord down and around the drive wheel and up and over the larger pulley of the whorl. Go down and around the drive wheel a second time. Bring the end of the cord up to the first end. Tie the two ends together using a square knot. Make sure that the drive band is very taut, since it will loosen some with use. Cut off the ends of the cord as close to the knot as possible.

For Scotch tension, use the same method above, except that only a single drive band is tied around the drive wheel and the whorl. If you are using the slow speed or extra slow speed whorls, it is best to tie a separate drive cord following the instructions above. Several drive cords can be left on the wheel at the same time. Just fold up the ones not in use and let them hang from the maiden or the front leg.

Using different flyer whorls

The type of fiber you are spinning and the kind of yarn you want to produce will determine which flyer whorl to use. Your spinning wheel comes with two flyer whorls: a Medium Speed Whorl with 9:1 and 11:1 ratios and a Fast Speed Whorl with 13:1 and 15½:1 ratios. We offer four others (see the chart). The general rules to remem-

ber are: the larger (slower) the whorl, the thicker the yarn, the less the twist, and the greater the take-up. It is also important to remember that, in the double drive mode, depending on how much or how little tension you put on the drive band, you can increase or decrease the take up. In the Scotch Tension mode the amount of take-up is controlled by the amount of tension you put on the brake spring & cord. The greater the tension, the greater the take-up.

The wood in your spinning wheel

We use hard maple and black walnut in the finest grades available. All our wood is kiln dried to assure its stability under a variety of conditions. Maple is a strong and beautiful hardwood that varies in color from pale cream to biscuit brown. It has a very fine grain that takes a high polish and is extremely resistant to abrasion. American black walnut grows wild as a tall tree of the rich bottomland forests throughout the central eastern and mid-western United States. It is also successfully cultivated in other parts of the U.S. and Canada. Black Walnut's deep brown heartwood beautifully accents the design of your wheel.

Wood is a natural breathing material, and like any natural material, it is affected

Whorl Ratio Chart	
Whorl	Ratio
Extra Slow Speed	4:1 & 4½:1
Slow Speed	6:1 & 7½:1
Medium Speed (with wheel)	9:1 & 11:1
Fast Speed (with wheel)	13:1 & 15½:1
*High Speed	17½:1 & 19½:1
*Super High Speed	18½:1 & 22:1
Bobbins: Regular Bobbin and High Speed Bobbin	
*these whorls use the High Speed Bobbin	

by its environment. Avoid placing your wheel near direct heat sources such as heat vents, wood stoves, space heaters, and direct sunlight. Heat concentrated on parts of the wheel can cause them to dry out and shrink. This shrinkage can cause weakness in the joints and the warping of parts. Likewise, place your wheel where it will be free of damp, moisture-laden air, as this can make wood swell and cause the moving parts to stiffen and function inefficiently.

The finish on your spinning wheel

The flyer of our spinning wheel has been lacquered to protect it from oil and moisture. The other parts of our wheel have been finished with Danish oil which penetrates into the wood, protecting the wood as well as the surface area. If you need to touch up parts of your wheel which have gotten chipped or scuffed, you can lightly sand the worn area and apply a small amount of finish using a soft lint-free

rag. Use either Deft or Watco natural color Danish oil. Both are available at most hardware stores. Follow the directions on the container. Because of the dangers of spontaneous combustion, be sure to clean and dispose of the applicators and oily rags according to the manufacturer's instructions.

Lubricating the moving parts

Before leaving the factory, your wheel was lubricated and tested. It may have been awhile since then, so it is a good idea to oil your wheel before starting to spin. Use a drop of oil on the following parts every couple of hours while spinning:

- front maiden bearing
- rear bearing
- bobbin bearings
- drive wheel bearings
- crank bearing(s) - sparingly

The flyer shaft should also be oiled where it touches the front and rear bearings and the bobbin bearings.

Use medium weight oil such as 20 or 30 weight motor oil.

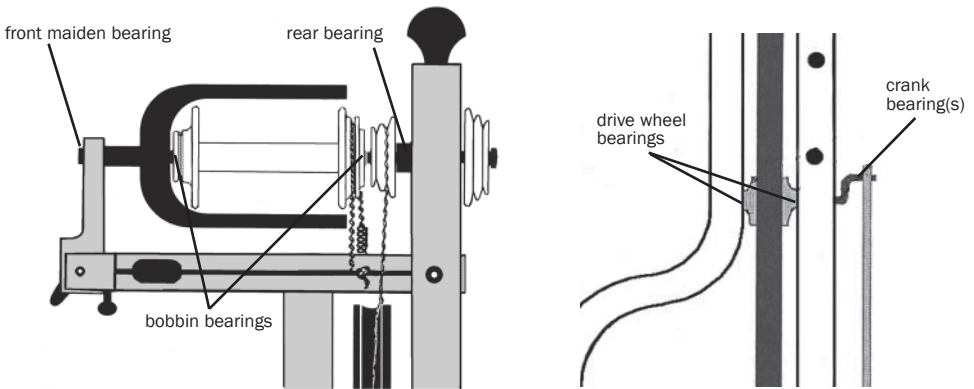

The Industrious Lazy Kate

Our Lazy Kate has an adjustable tension control cord which helps prevent bobbins from rotating too fast when releasing yarn. Place the bobbins in the Lazy Kate with the large bobbin end facing the tension cord. The handle ends of the bobbin rods should be on the side opposite the tension cord. Slip the tension cord over the grooves in the large pulley. Turn the control knob to increase or decrease the tension on the bobbins. Attach the small rubber rings to the tip ends of the bobbin rods to keep the rods in place.



Other Spinning Wheel Accessories

Spinning Wheel Cart

The neatest way ever to travel with your spinning wheel, the Schacht Spinning Wheel Cart is designed exclusively for the Schacht Spinning Wheel. The Cart comes with special hardware that replaces the bolts in the bottom of the spinning wheel rear legs. The rubber wheels give a smooth ride and they attach and detach quickly.



Oil Bottle

This is the perfect bottle for getting oil to all of those out of the way places on spinning wheels. It is useful for all kinds of household oiling jobs, too.



Dizzy Yarn Gauge

With both 1/2" and 1" measure, this gauge can be used as a spinner's yarn gauge, or a weaver's sett gauge. The hole in the center serves as a diz for making a consistent sliver for spinning.



Carders

We offer a wide selection of hand carders. They are made of maple. A molded lip on the rear edge of the paddle protects the card clothing from wear. The flared handle is very comfortable and reduces the amount of effort required in carding. Our wool carders are available in 72 and 112 points per square inch. Our 208 p.s.i. cotton carders are excellent for fine fibers, including cotton angora, and cashmere. Our flick carder, with 72 p.s.i., is a small single carder and is used to separate and tease fibers.



Spindles

Our drop spindles are available with 2½", 3" or 4" diameter whorls, and come with a brass hook so they can be used for either top- or bottom-whorl spinning. These spindles are good for spinning medium to long fibers, especially wool.



4" (3 oz.)

3" (2.2 oz.)

2½" (1.1 oz.)

Our pear tahkli support spindle has a hooked brass shaft and a maple bob. This spindle is excellent for spinning cotton and short, downy fibers.



Our Navajo spindle has a 30" tapered shaft and a 4½" maple whorl.



Maintenance Notes

Your wheel is both a carefully engineered piece of equipment and a fine piece of furniture. A regular schedule of care and maintenance will ensure you and your Schacht Spinning Wheel many productive years together.

- * Periodically clean excess fibers from all parts of your wheel.
- * Periodically lubricate the moving parts.
- * Touch up worn or chipped areas with fine sandpaper and Danish oil.
- * Check screws for tightness. (Changes in the environment and the action of spinning can cause screws and nuts to loosen over time.)

The serial # of your wheel is _____.

The serial number of your spinning wheel is stamped into the wood on the rear of the mother-of-all. (If the serial number on your wheel doesn't agree with the number written on this page, please reference the number stamped on your wheel).

Two Year Limited Warranty

Your new Schacht Spinning Wheel is warranted, to the original consumer purchaser, by Schacht Spindle Company, Inc. to be free of defects in material and workmanship. Schacht Spindle Company's obligation under this Warranty shall be limited to the repair or replacement of any part or parts which may prove defective within two (2) years following the date of original purchase by the consumer, and which Schacht Spindle Company's examination shall disclose to our satisfaction to be thus defective.

If a problem with this Schacht Spindle Company product develops during the warranty period, first contact the Schacht Spindle Company dealer from whom you made the purchase. If the problem cannot be handled through your dealer, then contact our customer service department. At our option, it may be required that the product be returned to our factory freight prepaid for inspection and repair and/or replacement.

This Warranty covers normal consumer use and does not cover damage which occurs in shipment or damage which results from alteration, accident, misuse, abuse, or neglect.

This Warranty gives you specific legal rights, and you may also have other rights which vary from state to state.