



# **Double Warp Beam**

For Standard and High Castle Floor Looms

Assembly Instructions

Schacht Spindle Co., Inc.  
6101 Ben Place Boulder, CO 80301 USA  
303-442-3212  
[www.schachtspindle.com](http://www.schachtspindle.com)

# Floor Loom Double Back Beam

## PARTS LIST

### Wood Parts:

- 1 - Double Back Beam Brake Release Pedal
- 1 - Double Back Beam Brake Hold
- 2 - Double Back Beam Fold up Supports (1-Left, 1-Right)
- 2 - Double Warp Beam Supports
- 1 - Double Square Beam (36" or 46")
- 1 - Special Double Warp Beam 36" or 46"  
(with attached brake hub and crank pivot bolt support)
- 2 - Apron Bars (36" or 46")
- 2 - Lease Sticks (36" or 46")

### Metal Parts:

- 1 - Double Back Beam Brake Pedal Assembly  
(Brake Bar, Brake Cable, Turnbuckle, Brake Release Upright)
- 1 - Warp Crank Bar
- 1 - Tapered Wood Handle with attached bolt, washer, and nut
- 2 - Double Back Beam Fold Up Knobs (w/longer shank)
- 1 - Brake Spring
- 4 - #12 x 3-1/2" Flat Head Wood Screws
- 8 - 1/2" Washers (large with 1/2" hole)
- 1 - 1/2" Cap Nut (with hole for pin)
- 1 - small pin to fix cap nut
- 1 - small wood block to assist in assembly of warp crank
- 2 - #14 x 1-3/4" Flat Head Wood Screws
- 1 - 1/2" x 2-1/2" Hex Head bolt
- 1 - 1/2" Lock Nut
- 1 - 5/16" x 2-1/4" Carriage Bolt
- 1 - 5/16" x 2-1/2" Carriage Bolt
- 9 - 1/4" Washers (small with 1/4" hole)
- 2 - 5/16" Hex Nut
- 2 - 5/16" Locking Hex Nut (thicker with plastic inside rim)
- 1 - #12 x 1-1/2" Flat Head Wood Screw
- 7 - 48" Apron Cords for 36"  
or
- 9 - 48" Apron Cords for 46"

### Required Tools:

- Phillips screwdriver
- Slotted screwdriver
- 7/16" wrench
- 2 - 3/4" wrenches
- Drill and 3/16" drill bit
- Hammer

Note: Rubbing a little wax or bar soap on the screw threads will make the screws easier to turn.

### Notes:

*If your loom was made before January 1, 1990, please see the instructions on page 8 before beginning the installation of the double back beam.*

*If you intend to put a sectional beam on the second warp beam, be sure to let us know when you order that it is for the second warp beam.*

## Install the Double Warp Beam Supports and the Double Warp Beam (Figure 1)

“Right” and “left” in steps 1-4 refer to loom parts as seen from the rear of the loom.

1. Attach one double warp beam support to the right rear leg of the loom with a 3-1/2” flat head wood screw at the top only (do not secure the bottom yet). Do not tighten the screw all the way. Make sure the smaller hole at (c) on the side of the support is towards the top of the loom.

2. Attach the other double warp beam support to the left rear leg of the loom with a 3-1/2” screw at the top and the bottom. Be sure the smaller hole at (c) is towards the top of the loom. Do not tighten all the way.

3. Place one 1/2” washer on the threaded axle and install the threaded axle into the bottom hole in the left double warp beam support. There are 2 extra washers provided, so that if the beam is loose, you can add another washer to this axle and/or to the axle at the other end (see Step 4). Note that the new warp beam handle will be mounted on the threaded axle so that the handle for the double warp beam is on the same side as the handle for your existing warp beam.

4. Place a 1/2” washer on the non-threaded axle on the right end of the second warp beam and insert it into the bottom hole of the right double warp beam support. Pivot the support out a little bit to accomplish this. Secure the bottom of the support with the remaining 3-1/2” flat head wood screw and tighten it and the top screw. The warp beam should spin freely. If it is too tight, loosen all the 3-1/2” screws slightly and rotate the beam a few times. Then retighten the screws.

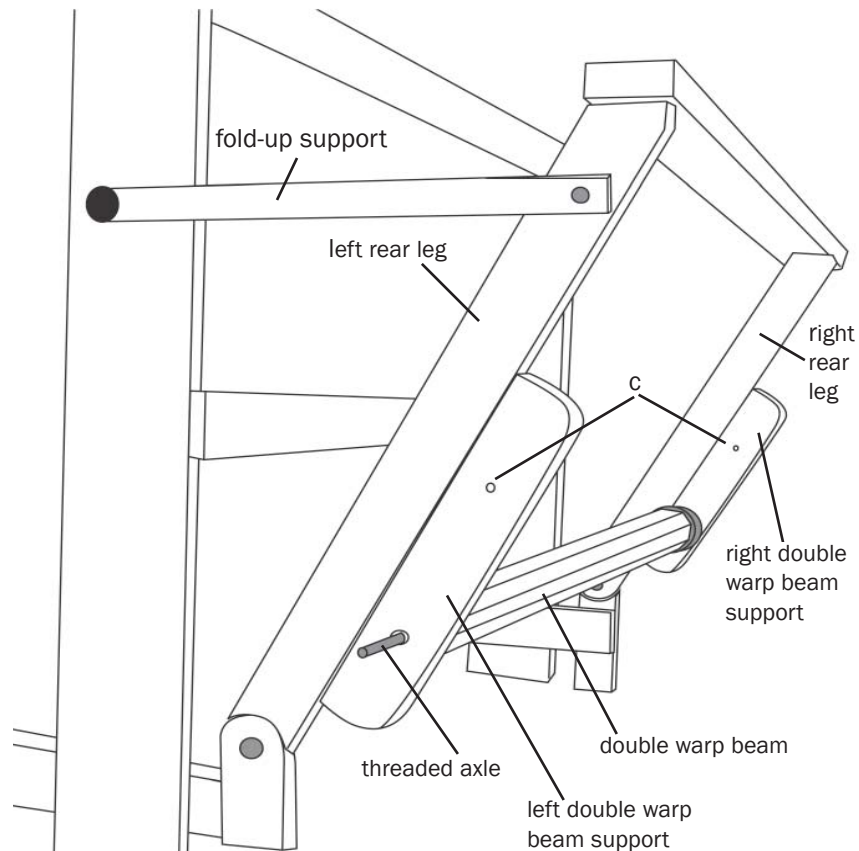

Figure 1  
(view toward the back of the loom)

### Install the Brake Handle on the Double Warp Beam (Figures 2a and 2b)

5. Place another 1/2" washer on the threaded axle of the double warp beam on the outside of the left leg. Slip the crank handle onto the threaded axle with its larger hex opening of the crank handle facing out.

6. Screw the cap nut onto the threaded axle, and tighten approximately 6 turns, stopping so that the hole in the cap nut lines up with the hole in the bolt. Hold the wood block under the nut and, with a hammer, tap the pin through the nut and the bolt until it is flush with the bottom side of the nut. Attach the wood handle by undoing the nut on the crank handle and inserting the bolt thru the metal crank handle. Using one 7/16" wrench and one 3/4" wrench, fasten the locknut. Leave enough room for the wood handle to turn freely.

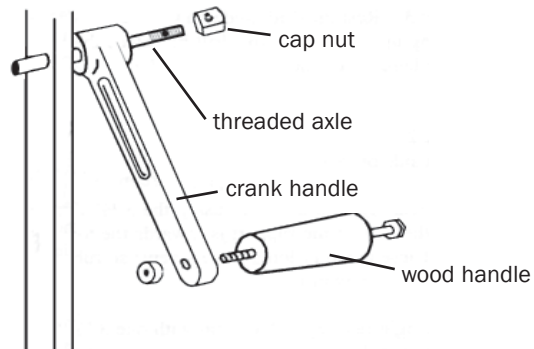

Figure 2a

### Install New Fold-up Supports (Figure 3)

7. Replace both of the original fold-up supports with the new double back beam fold-up supports. First remove the original black knobs and the nylon washers from the old fold-up supports. Undo the screws at (s) to remove the old fold-up supports. Install each new double back beam fold-up support to each rear leg at (s) with a 1-3/4" flat wood screw. Check that the angled "leg" for the double square beam extends upward. Remove the nylon washers from the old black knobs and install them on the new longer knobs. Attach the double back beam fold-up supports to the castle with the new black knobs.

8. Place the double square beam on the double square beam legs (see figure 3).

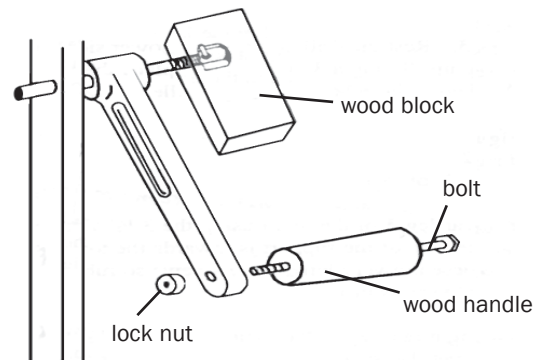

Figure 2b

### Attach the Brake Release System (Figures 4 and 5)

9. Place a 1/2" washer on the 1/2" x 2-1/2" hex head bolt, and insert the bolt through hole (a) in figure 4 in the right (as viewed from the rear) side brace from the outside to the inside of the loom. Place another 1/2" washer over the bolt.

10. Remove the carriage bolt at (b) in figure 4 and replace it from the outside to the inside of the loom with the 5/16" x 2-1/4" carriage bolt provided. Tap the new bolt into place by aligning the square hole in the wood with the square shaft of the carriage

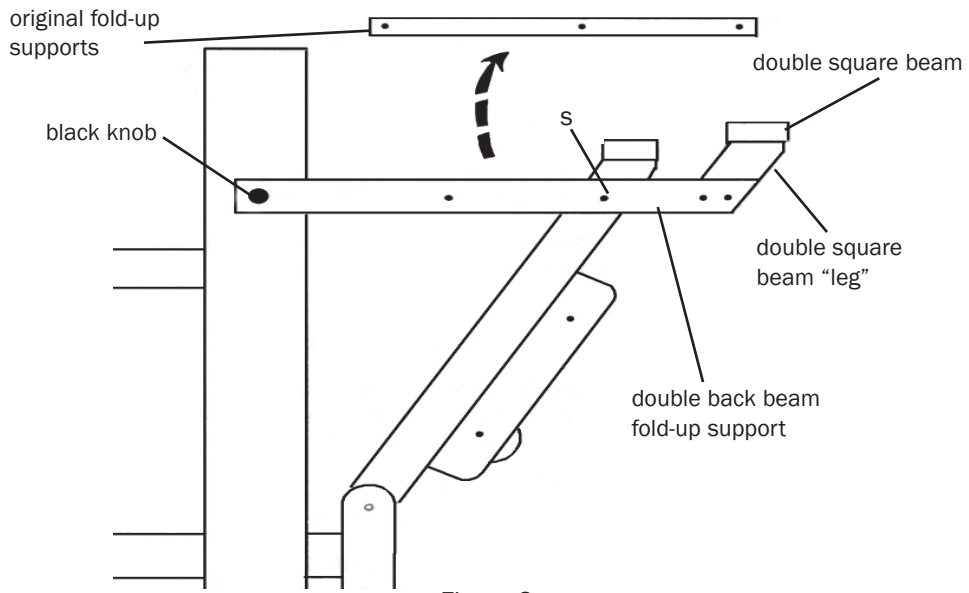

Figure 3

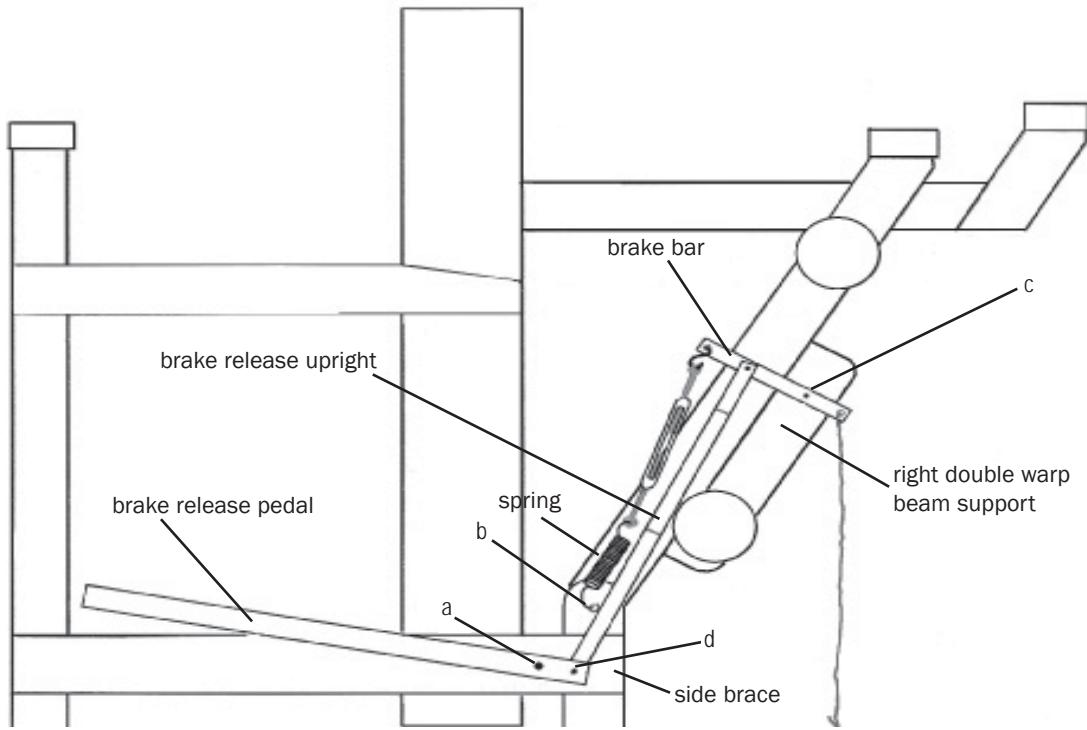

Figure 4

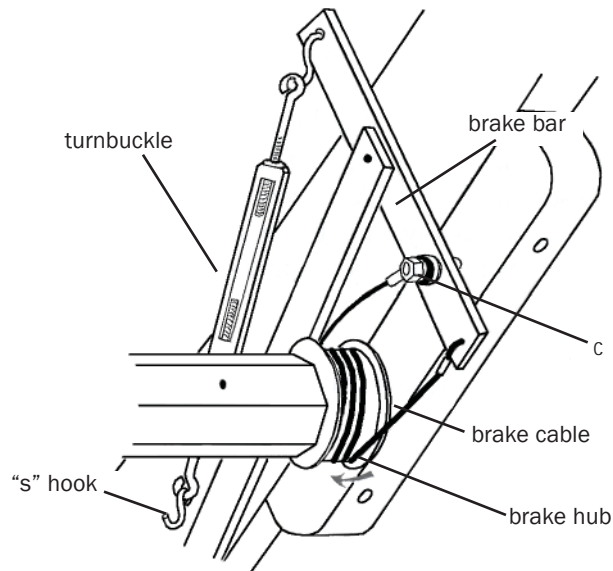

Figure 5

bolt. Place a 1/4" washer and a regular (not locking) hex nut on the carriage bolt. Tighten the nut all the way until the carriage bolt head is drawn into the wood, then loosen the nut three-quarters of a turn, allowing the rear leg to pivot easily.

11. Attach the 5/16" x 2-1/2" carriage bolt in the small hole at (c), on the double warp beam support on the right rear leg (as viewed from the rear). Install the bolt from the outside to the inside of the support. Add a 1/4" washer and a 5/16" hex nut, and fasten the nut tightly so as to pull the square shaft of the bolt into the wood on the outside of the support.

12. Lay the double warp beam brake pedal assembly out on the floor so that the brake release pedal, the brake release upright and the brake bar are aligned as in figure 5.

13. Remove the lock nut and washer from the brake pedal assembly at (d). Attach the brake release upright to the brake pedal assembly with the lock nut and washer using a slotted screwdriver and a 7/16" wrench. Tighten then loosen the lock nut so the assembly can pivot freely. Put three 1/4" washers on the bolt at (c). Lift up the brake release assembly and place the brake pedal on the bolt at (a) and the brake bar on the bolt at (c). Let the brake cable and turnbuckle just hang

loose for now. Put a 1/2" washer on the bolt at (a) and secure it with the 1/2" locknut using two 3/4" wrenches.. Make sure the brake pedal can still pivot freely.

### Install the Brake (Figures 4 and 5)

14. Put another 1/4" washer on carriage bolt at (c). Sitting on the floor in back of your loom, wrap the brake cable around the brake hub three times, wrapping under to over from the outside of the loom towards the inside. Place the loop on the end of the cable over the carriage bolt at (c) and secure it with another 1/4" washer and a lock nut. Be sure that the brake bar is able to pivot freely.

15. Put a 1/4" washer on the carriage bolt at (b) in figure 4. Place the bottom loop of the brake spring over the bolt at (b) followed by another 1/4" washer. Add a lock nut to the bolt and tighten the nut enough to keep the spring in place, while still allowing it to pivot freely.

16. Attach the top end of the brake spring to the "S" hook on the bottom of the turnbuckle.

17. Tighten the turnbuckle so that the spring just begins to stretch. By turning the turnbuckle one way or the other, you can adjust the tension of the warp beam. Lengthening the spring increases the tension on the brake cable.

**Install the Brake Hold (Figure 6)**

18. The brake hold allows you to keep the double back beam brake pedal depressed at the left side of your loom while you are winding on or advancing your warp on the right side of your loom.

Measure in 3" from the front end of the upper left side support and centered in the side support. Using a 3/16" drill bit, drill a hole 3/4" deep at point (d) in figure 7. Attach the double back beam brake hold with the 1-1/2" flat head wood screw. Tighten this screw all the way then loosen it just enough to allow the brake hold to pivot freely.

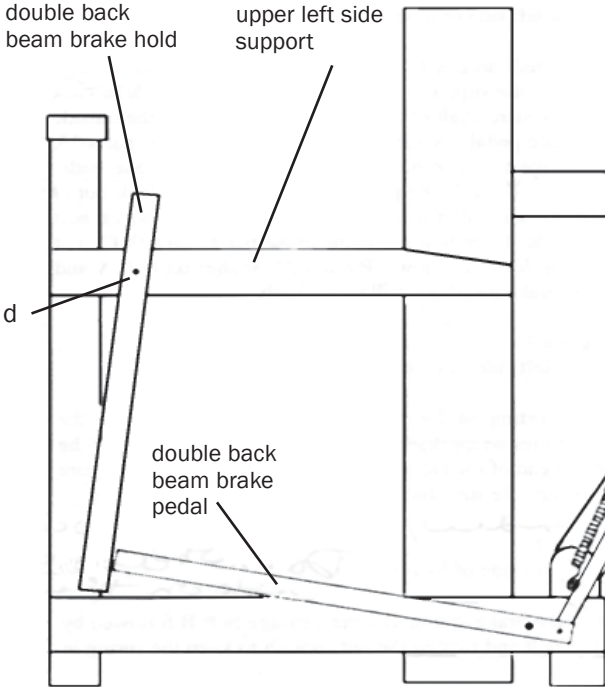

Figure 6  
(left side of loom, viewed from the inside)

## DOUBLE WARP BEAM PREPARATION INSTRUCTIONS FOR STANDARD AND HIGH CASTLE FLOOR LOOMS

For looms manufactured before January 1, 1990, you will have to drill holes in the rear legs of your loom, as described in this section. If your loom already has these holes, proceed to the installation instructions.

Parts: two drill guides  
Tools: a 3/16" and a 1/2" drill bit.

1. Fold up the rear warp beam and secure it with the fold-up supports.
2. Place the drill guide X over the back of each rear leg as shown in figure A. Rest the drill guide on the lower side brace and be sure the end marked TOP is facing up. Using a 3/16" drill bit, and using the drill guide as a jig, drill a 1 1/2" deep hole in the rear legs at each of the two holes in the drill guide.
3. Place the drill guide Y on the side brace as shown in figure B. Position the drill guide so that it butts up against the rear leg. Using a 1/2" bit, drill a hole through the lower side brace. Please note: It is very important that the hole is drilled as straight and as cleanly as possible. To accomplish this, drill from the outside of the loom until the drill bit just starts to come through the inside of the lower side brace. Then remove the drill and drill the rest of the hole out from the inside of the loom. Be sure to hold the drill level and square to the lower side brace.

Figures A and B (view from outside of right side of loom)

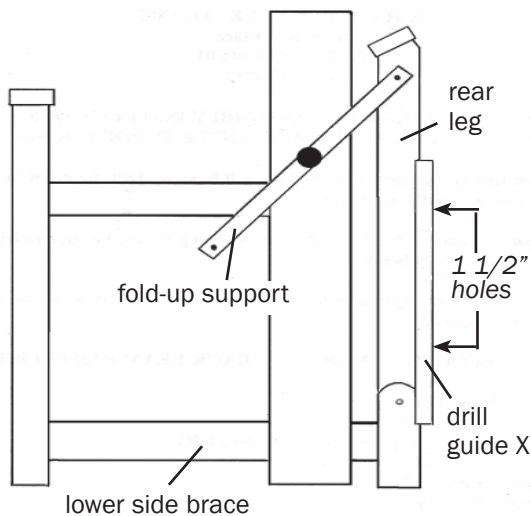

Figure A

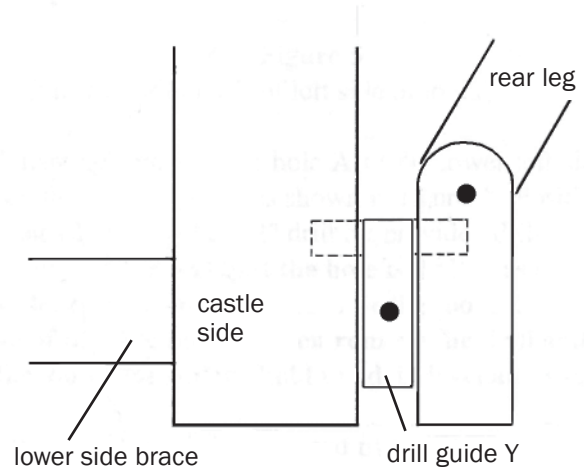

Figure B