

STANDARD FLOOR LOOM

ASSEMBLY INSTRUCTIONS



Find out more at schachtspindle.com
Schacht Spindle Company 6101 Ben Place Boulder, CO 80301
p. 303.442.3212 f. 303.447.9273

© 2011 Schacht Spindle Company, Inc.

04.11

FLOOR LOOM

ASSEMBLY INSTRUCTIONS

TOOLS

7/16" or adjustable wrench

1 - 1/2" and 1 - 9/16" wrenches or

2 adjustable wrenches

rubber mallet or hammer and scrap wood

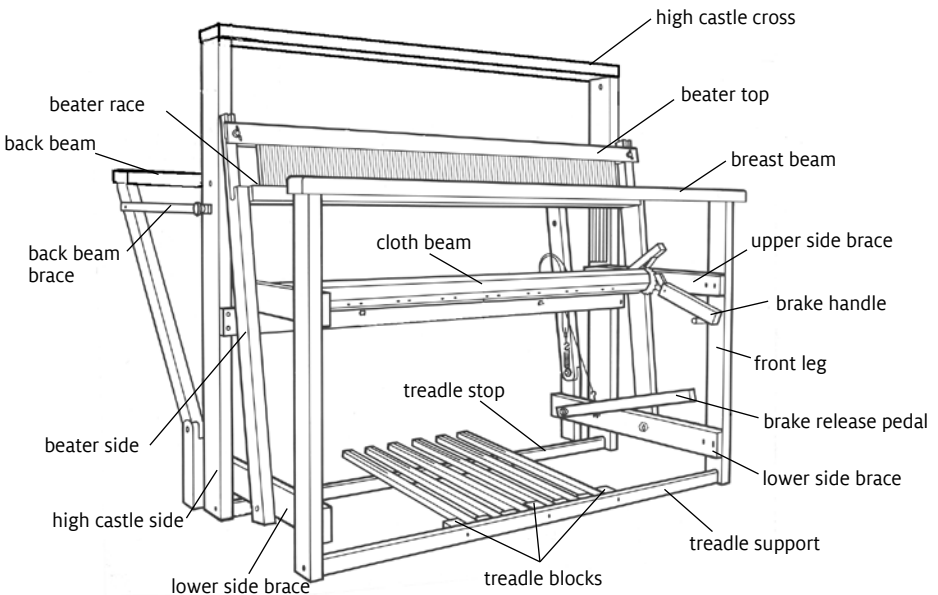

*HIGH CASTLE FLOOR LOOM
FRONT VIEW*

UNFOLDING THE BACK BEAM

When you receive your loom the back beam will be folded up against the castle. It is fastened in position with a black fold knob which passes through the back beam brace and fastens into a metal insert in the castle side. To extend the beam for weaving, remove the knobs from both sides of the loom. Hold on to the back beam and ease it back until the hole at the end of the brace lines up with the insert in the castle. Place the knob in the hole and tighten. Line up the other brace and secure it. Your loom is now in weaving position.

ATTACHING THE WARP BEAM CRANK HANDLE

The warp beam crank handle is hanging on a rod on the right rear loom leg. To attach the wood handle, slide the washer onto the long bolt, then put the bolt through the hole in the end of the metal crank. Fasten with the lock nut (figure 1). Leave the lock nut just loose enough so the handle can rotate freely. Use one 1/2" wrench and one 9/16" wrench (or two adjustable wrenches) to do this job.

To engage the crank for turning the warp beam, pull the crank onto the cap nut. While weaving, the crank should be pushed back to hang loosely on the rod (figure 2).

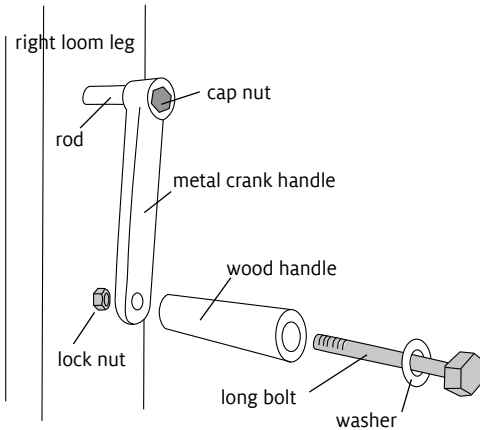

FIGURE 1 - WARP BEAM CRANK HANDLE
(RIGHT SIDE OF LOOM)

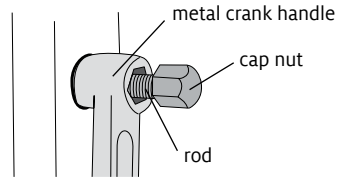

FIGURE 2 - WARP BEAM CRANK HANDLE
IN WEAVING POSITION

ADJUSTING THE FRICTION BRAKE

Adjust the friction brake action by tightening or loosening the turnbuckle. To see if the friction brake is adjusted properly, run the following test. Stand at the rear of the loom. Grip the warp beam firmly with both hands. Try to turn the warp beam away from you (if you view the beam from the left side of the loom you would be turning the beam in a clockwise direction).

If the beam turns at all, tighten the turnbuckle a few turns (figure 3). If it still turns, tighten the turnbuckle again. Repeat until the warp beam will not turn under a good amount of pressure.

Now depress the brake release pedal at the front of the loom. While the brake release pedal is down you should be able to turn the warp beam easily in the clockwise direction. Remember to press the brake release pedal whenever you are winding or unwinding the warp beam. The wing nut under the back of the brake release pedal can be used to set the pedal to your preferred angle.

THE BRAKE RELEASE HOLD

The brake release hold is used to keep the brake release pedal depressed when you are winding on the warp. Push the brake release pedal down and adjust the brake hold by pulling it out and slightly back so it is wedged against the brake release pedal holding it in the release position (see figure 7).

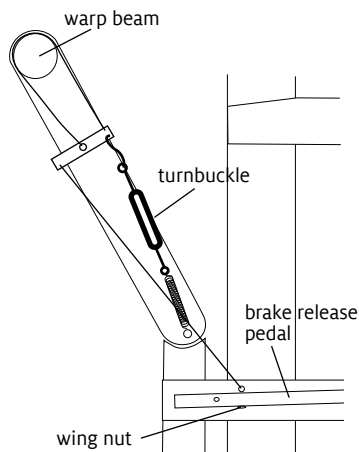

FIGURE 3 - VIEW FROM INSIDE LOOM

ATTACHING THE APRON BARS

There is one cord for each hole in the cloth and warp beams. Insert one end of a cord through a hole in the beam and pull the cord through. Then insert the other end through the second hole in the end of the cord that you just put through the beam. Pull firmly on the cord to tighten (figure 4 - A). Repeat across the cloth beam and the warp beam.

To attach the apron bar to the apron cords, take a pinch of the cord about 4" from the end (figure 4 - B). Insert the pinched cord through the second hole in the cord. Pull on the pinched cord until a new loop

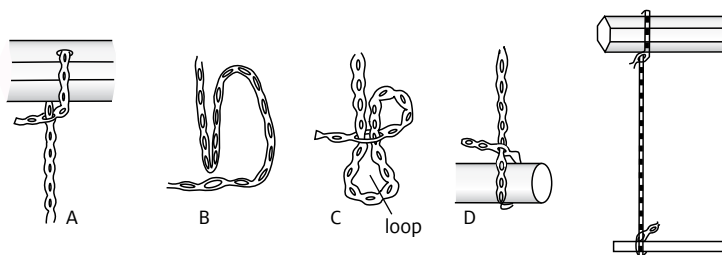

FIGURE 4

forms that is large enough for the apron bar to slip through (figure 4 - C). Slide the apron bar through the loop (figure 4 - D) and pull tight. Repeat until all cords are attached to the apron bar. Attach the other apron bar to its beam in the same way.

INSTALLING THE HEDDLES IN THE HARNESS FRAMES

If your loom has a high castle, first remove the entire tray assembly (see Removing Harnesses on High Castle Looms). Remove the nut from the jack pin at the bottom of each harness (figure 5). Lift a harness from the loom castle by lifting it straight up. Lay the harness flat on a table. Release the heddle bars from the lock hooks that hold them in the harness. Bend the heddle bars just enough to remove one end from the slot in the the harness frame. Pull the other end out of the opposite slot in the harness frame

Carefully slide the number of heddles that you need onto the heddle bars. This is best done by holding a small group of heddles firmly together (figure 6), sliding one end of the heddle group onto the upper heddle bar and then sliding the other end of the heddle group onto the lower heddle bar. Do not let the heddles slip out of place while transferring them. Replace the

heddle bars in the harness frame by bending the bars slightly. Replace the harness in the castle, insert the jack pin into the hole in the bottom of the harness frame and fasten with the nut (figure 5). Repeat for each harness.

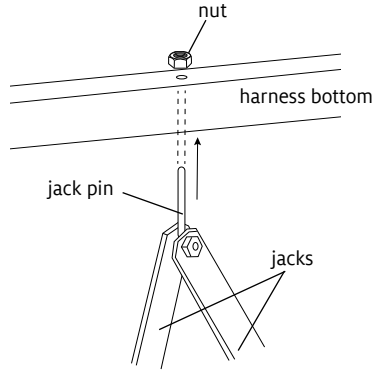

FIGURE 5

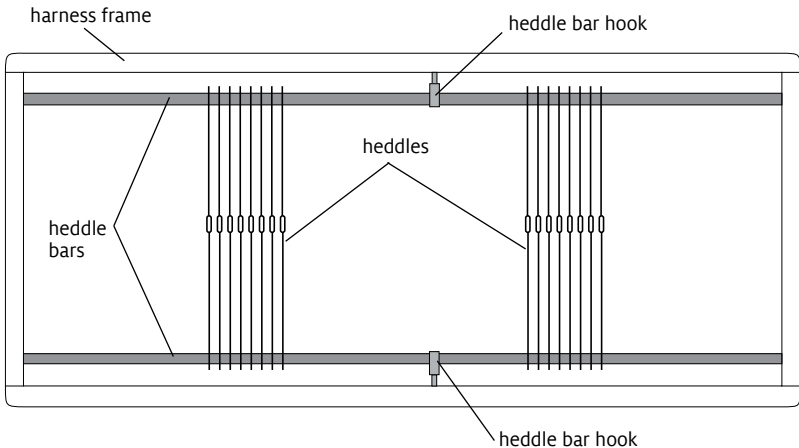

FIGURE 6

REMOVING HARNESSES ON HIGH CASTLE LOOMS

To remove the harnesses from the castle you must first remove the accessory tray from the top of the castle. Using a 7/16" wrench, loosen the two bolts at either end of the tray. Lift the tray straight up to remove it. You may need to give it a tap with a rubber mallet from underneath. (If you do not have a rubber mallet you can use a hammer with a block of wood to protect the loom from the hammer). Be sure to tighten the bolts after the tray is put back on. This adds to the loom's stability.

BEATER HEIGHT ADJUSTMENT

The height of the beater has been set at the factory to suit the average weaver for most projects. However, if you want to raise or lower the beater, loosen the two nuts on the inside of each of the metal beater pivots. Position the beater at the desired height and tighten the nuts. Be sure that you have set the height of each side of the beater equally (figure 7).

INSTALLING THE TIE-UP CORDS

There is one tie-up cord for every lamm hole: 24 for a 4-shaft loom; 80 for an 8-shaft and 4 now-4 later looms; 96 for 8-shaft and 4 now-4 later looms with 12 treadles. Loop one end of each tie-up cord through a hole in the lamm. On looms with twelve treadles, the tie-up cords are inserted through the hollow pin at the end of each lamm (figure 7).

Work from the front lamm to the rear lamm for each treadle. Loop one end of the tie-up cord through the lamm as illustrated. Slip the cord through the slot in the treadle. After you have completed tying-up your treadles push each one all the way to the floor and then lift it back up. Make sure that the plastic button of the tie-up cords are all the way against the treadle.

On looms with twelve treadles, the tie-up cords are inserted through the hollow pin at the end of each lamm.

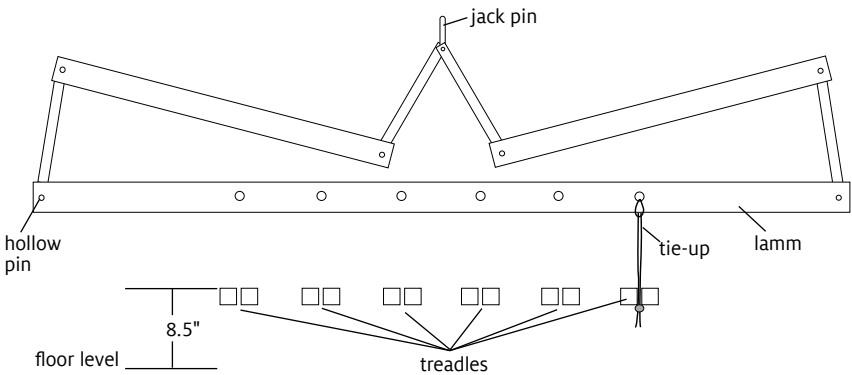

FIGURE 7

TYING THE SHAFTS TO THE TREADLES

Work from the front lamm to the rear lamm for each treadle. Loop one end of the tie-up cord through the lamm as illustrated. Slip the cord through the slot in the treadle. After you have completed tying-up your treadles push each one all the way to the floor and then release it. Make sure that each cord hangs straight down to the treadle.

LAMP HOLDER

The two holes, one in the top of each castle side, are designed to accommodate the swivel pin of an extension-style lamp.

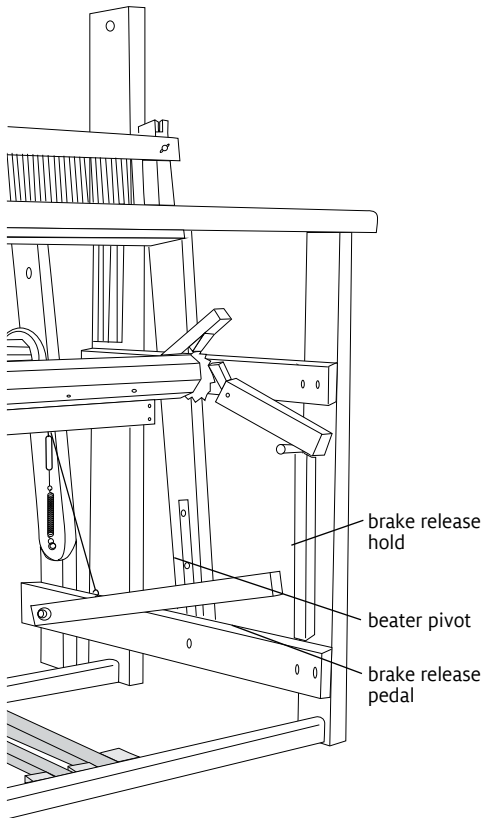

FIGURE 7

ACCESSORIES FOR SCHACHT FLOOR LOOMS



Double Back Beam
(in Maple or Cherry)



Sectional Warp Beam
(in Maple or Cherry)



Tension Box
for Sectional Warping



Loom Bench with Bench Bags
(in Maple or Cherry)



Spool Rack
for Sectional Warping