

# STANDARD FLOOR LOOM

## EXPORT ASSEMBLY

### HARDWARE LIST

2 – Black fold knobs  
2 – Nylon washers  
8 – 1/4" x 2-1/2" Trusshead screws  
8 – 1/4" Barrel nuts  
2 – 5/16" x 2-1/2" Carriage bolts  
8 – 1/4" Washers  
2 – 1/4" Lock nuts  
2 – 5/16" Wing nuts  
2 – 5/16" Lock nuts  
6 – 1/2" Washers  
1 – 1/2" Cap nut  
12 – #12 x 1-1/2" trusshead screws  
2 – 5/16" x 1-3/4" hex head bolts  
1 – Crank handle

### For 8 Harness Add:

2 – 3/8" x 6-1/8" Jack pivot rods  
2 – 1/4" x 7" Carriage bolts  
22 – 3/8" Washers  
8 – 8/32" Hex nuts

### For 4 Now 4 Later Add:

2 – 3/8" x 6-1/8" Jack pivot rods  
2 – 1/4" x 7" Carriage bolts  
6 – Nylon spacers  
18 – 3/8" Washers  
4 – 8/32" Hex nuts

### For High Castle Add:

12 – #8 x 1-1/2" Trusshead screws  
2 – 1/4" x 1 1/2" Hex head bolt  
2 – 1/4" Washers



Find out more at [schachtspindle.com](http://schachtspindle.com)  
Schacht Spindle Company 6101 Ben Place Boulder, CO 80301  
p. 303.442.3212 f. 303.447.9273

© 2011 Schacht Spindle Company, Inc.

04.11

**ASSEMBLY INSTRUCTIONS**

- Unpack the floor loom parts carefully. Do not throw away the carton or any of the packing material until you have checked to see that all the parts and hardware have been received.
- All hardware is sized in inches. Illustrations of the various hardware and a inch scale are provided to aid you in determining the correct screw and size to use.
- Before starting the assembly, read the instructions completely and familiarize yourself with the drawings and parts.
- Follow the exact order of assembly. Take care and work slowly. Assembly is easier if you have someone help you.
- When you finish assembling the floor loom, go back over all of the screws and make sure they are tight. It is a good idea to retighten the screws every few months. Remember not to tighten those screws and bolts which are supposed to allow their parts to pivot freely.
- All parts of the floor loom have been finely sanded and finished with a hand rubbed Danish oil. From time to time you may wish to apply more finish to the loom. Use a Danish oil (tung oil and polyurethane mixture) and rub the wood with a soft, lint free cloth.

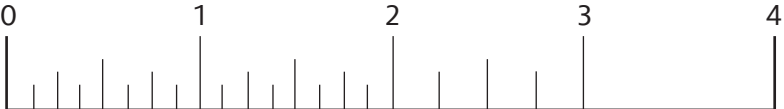
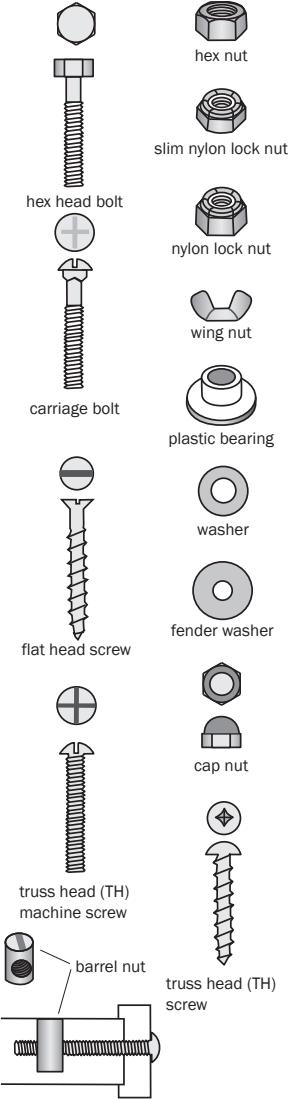

**INCH SCALE**

## FIGURE 1

1. Attach the left and right rear beam support braces (3 & 4) to the threaded inserts in the left and right castle sides (1 & 2) using the black knobs (B) and nylon washers. Use the holes in the very end of the braces. The holes in the middle of the braces are used for the folded position.
2. Stand the loom sides up and fit the ends of the treadle cross support (5) into the slots in the bottom of the front corner posts (6 & 7) and bolt (1/4" x 2-1/2" trusshead screw) them together using the barrel nuts. The barrel nut is placed in the hole on the rear side of the treadle cross support. Fit the screw into the holes in the front corner post and the treadle cross support. Rotate the barrel nut until the screw can be threaded into it.
3. Attach the treadle stop (1/4" x 2-1/2" trusshead screws) (8) in the same way.

## FIGURES 2 & 3

1. Take the cloth beam (12) and place a 1/2" washer, the ratchet lever (14), and another 1/2" washer on the metal pin (P). Be sure that the ratchet pawl (15) is on the upper side of the ratchet gear.
2. Raise up the ratchet gear dog (16) and fit the metal pin (P) into the hole in the right side brace. (17).
3. Hold the cloth beam (12) level with your right hand and slightly spread apart the loom and insert the pin in the other end of the cloth beam into the hole in the left side brace (18).
4. Screw (#12 x 1-1/2" trusshead screw) the front castle cross brace (19) to the front of the castle sides (1 & 2). Make sure the square holes of the castle cross brace face up.
5. Put the front beam (20) in place. The rounded edges of the front beam face the front of the loom.

## FIGURE 3 & 4

1. Lay the left beater side (21) and the right beater side (22) on the floor. Place the beater shuttle race (23) between the left and right beater sides. Fit the beater shuttle race into the cross cuts. Secure (1/4" x 2-1/2" trusshead screw) each beater side to the beater shuttle race, using two barrel nuts inserted into the holes in the bottom of the beater shuttle race. The back of the shuttle race and the back of the sides fit flush to each other.
2. Place the reed (25) in the slot of the beater shuttle race. Center it between the left and right beater sides.
3. Fit the beater top (24) onto the reed and between the left and right beater sides, and bolt (5/16" x 2-1/2" carriage bolts) it to the left and right beater sides. The square collar of the carriage bolt fits into the slots in the beater sides. Secure the beater hand bar with 1/4" washers and 5/16" wing nuts (W).
4. Place the whole beater in position on the loom. The left and right beater sides (21 & 22) fit to the outside of both upper and lower side braces. Bolt (5/16" x 1-3/4" hex head bolt) the beater sides to the lower side braces (26 & 27). Put a 1/4" washer on the hex head bolt. Place another 1/4" washer between the beater side and the lower side brace. Put a washer on the bolt, then secure with the 5/16" lock nut.

## FIGURE 5 & 6

**Each jack mechanism is marked with a number from 1-4. The jacks are installed in pairs. The 4-Now-4-Later loom has two #1 jacks and two #2 jacks; the 8-shaft loom has two of each jack numbers 1-4.**

### *For 8 Shaft Looms*

1. At the rear of the loom, insert the 3/8" x 6-1/8" jack pivot rods (A) into the larger holes of the front castle cross brace (19).

**2.** Place two 3/8" washers on each of the rods (A). Place a #1 jack mechanism on the rods (A). Place a 3/8" washer on each rod, followed by the second #1 jack mechanism. Continue in the following order: another washer, a #2 jack mechanism, a washer, another #2 jack mechanism, a washer, a #3 jack mechanism, a washer, the second #3 jack mechanism, a washer, a #4 jack mechanism, a washer, and the second #4 jack mechanism. Finish by placing two more 3/8" washers on each rod. Insert the 1/4" x 6-1/8" jack stop rods (S) into the small holes above the jacks.

**3.** Attach the rear castle cross brace (30) to the rear castle sides (1 & 2) with (#12 x 1-1/2" trusshead screw). Make sure the rods (A) fit into their correct holes.

**4.** Insert the 1/4" x 7" carriage bolt through holes (S) in the front castle cross brace (19) and on through the holes (T) in the rear castle cross brace (30). Align the square part of the carriage bolts in the square holes (S) and tap it firmly into the holes. Put a washer on each bolt and secure with a 1/4" lock nut. Do not tighten the lock nut all the way. The washer should remain loose. Push the jacks (J) down in the center to allow the carriage bolt to go across the jacks easier.

#### *For 4-Now-4-Later Looms*

**1.** Place two 3/8" washers on each of the rods (A). Place a #1 jack mechanism on the rods (A). Place a 3/8" washer on each rod, followed by the second #1 jack mechanism. Place another washer, a #2 jack mechanism, a washer, and another #2 jack mechanism. Then put on one 3/8" washer, 3 nylon spacers and one or two 3/8" washers as needed on each of the rods (A).

**2.** Attach the rear castle cross brace (30) to the rear castle sides (1 & 2) with (#12 x 1-1/2" trusshead screw). Make sure the rods (A) fit into their correct holes.

**3.** Insert the 1/4" x 7" carriage bolt through holes (S) in the front castle cross brace (19) and on through the holes (T) in the rear castle cross brace (30). Align the square part of the carriage bolts in the square holes (S) and tap it firmly into the holes. Put a washer on each bolt and secure with a 1/4" lock nut. Do not tighten the lock nut all the way. The washer should remain loose. Push the jacks (J) down in the center to allow the carriage bolt to go across the jacks easier.

#### **FIGURES 7 & 8**

**1.** Take the warp beam (31) and place a 1/2" washer on the metal pin in the end opposite the brake drum (D). Place a 1/2" washer on the threaded rod (R) in the brake drum (D) and slip the treaded rod through the hole in the right rear beam support (32). Fit the pin in the other end into the hole in the left rear beam support (33). You will have to slightly spread apart the right and left rear beam supports to accomplish this.

**2.** Assemble the tapered wooden handle (34) to the warp beam crank handle (35) with the 5/16" x 4" hex bolt and nylon lock nut. Place a 1/2" washer over the threaded rod (R). Slide the crank handle (35) over the threaded rod. Make sure the larger hex opening of the crank handle faces out. Screw the 1/2" cap nut (P) onto the end of the threaded rod.

**3.** Remove the nut (N) and washer and the cable (C) from the bolt (B). Unwrap the cable (C) and rewrap it around the brake drum (D). Wrap the cable around the brake drum three times going from the left to the right. Press the brake pedal (15) and put the cable (C) and washer and the nut (N) back on the bolt (B). Be sure to rewrap the cable just as it is illustrated in figure 7.

**4.** Adjust the friction action by tightening or loosening the turnbuckle (T). To see if the friction brake is adjusted properly,

do the following: Stand at the rear of the loom. Grip the warp beam (31) firmly with both hands. Try to turn the warp beam away from you (if you view the beam from the left side of the loom, you would be turning the beam in a counter-clockwise direction). If the beam turns, tighten the turnbuckle nut a few turns. Try to turn the beam again in the same direction. If it still turns, tighten the turnbuckle again. Do this until the warp beam will not turn under a good amount of pressure. Now, have someone press the front of the brake lever (15) down. While the brake lever is held down, you should be able to turn the warp beam easily in either direction.

**NOTE: You will be able to turn the warp beam in the counterclockwise direction whether the brake lever is up or down. Remember to press the brake lever whenever you are winding or unwinding the warp beam.**

#### *For Low Castle Looms*

5. Put the back beam (37) in place on the right and left rear beam supports (32 & 33). Make sure the rounded edges of the back beam face the rear of the loom.
6. Screw (#12 x 1-1/2" trusshead screw) the upper castle cross brace (36) to the rear of the castle sides (1 & 2). This piece is identical to the castle cross braces except it does not have any holes in it other than the four counter-sunk screw holes.

#### **FIGURES 9 & 10**

#### *For High Castle Looms*

1. Assemble the high castle loom tray. Screw (#8 x 1-1/2" trusshead screw) the tray front (41) to the tray end pieces (42) and the center piece (44). Slip the tray bottoms (43 & 46) into the slots of the tray front. Fit the tray rear (40) to the tray end pieces (42 & 45) and center piece (44) and screw (#8 x 1-1/2" trusshead screw) it together.

2. Screw (1/4 x 1-1/2" hex head bolt) the tray bolts (T) with a 1/4" washer on it, into the castle sides (1 & 2). Fit the loom tray between the castle sides and tighten the bolts.

3. Put the back beam (37) in place on the right and left rear beam supports (32 & 33). Make sure the rounded edges of the back beam face the rear of the loom.

#### **FIGURE 11**

1. You need to transfer the heddles to the heddle bars (51) and insert them into the shafts before you thread your loom. Lay a shaft frame flat on a table or on the floor. Push the heddle bar lock hook (52) up to release the heddle bar. The heddle bars are made of spring steel and may be gently bent without damage. Bend the heddle bar enough to remove one end from the slot in the end of the shaft frame. Pull the other end of the heddle bar out of the other side of the shaft. Remove both top and bottom heddle bars.

2. Carefully slide the heddles onto the heddle bars. This is best done by holding small groups of heddles firmly together, sliding one end of the heddle group off of the string and on to one of the heddle bars, then sliding the other end of the heddle group onto the other heddle bar. Try not to let the heddles slip out of place while transferring them. Transfer the number of heddles you need and replace the heddle bars in the shaft frame.

3. Place the shaft frames (50) back in the castle. The heddle bar lock hooks are slightly off center and should be lined up on the same side of center when the harnesses are in the castle. Be sure the jack pin (JP) is properly inserted into the hole in the center of the bottom of the shaft frame. Put the nut (N) on the jack pin.

## FIGURE 12

1. Locate the pre-cut looped apron cords. There is one cord for each hole in the cloth and warp beams. To attach the apron cords to the beams, insert one end of the cord through a hole in the beam and pull the cord through a few inches. Take the other end of the cord and put it through the second loop in from the end that you put through the beam. Pull firmly on the cord to tighten it around the beam (Diagram A).

2. Repeat this procedure across each of the beams. To attach the apron bar to the apron cords, start at one end of the beam with the outermost cord and work across. Fold the end of the looped cord at about 4" from the end and insert this doubled cord through the second loop from the end of the cord (Diagram B). Slide the apron bar through the loop formed by the doubled over cord at point X. Pull the cord tight (Diagram C). Repeat across the entire beam.

## FIGURE 13

Loop one end of the tie-up cord through the lamm with a lark's head knot. Slip the cord through the slot in the treadle. The tie-up cord should hang straight down to the treadle and not be angled forward or back. Work from the front lamm to the rear lamm for each treadle. After you have completed tying up your treadles push each one all the way to the floor and then let it back up. The plastic button of the tie-up cord should be against the treadle.

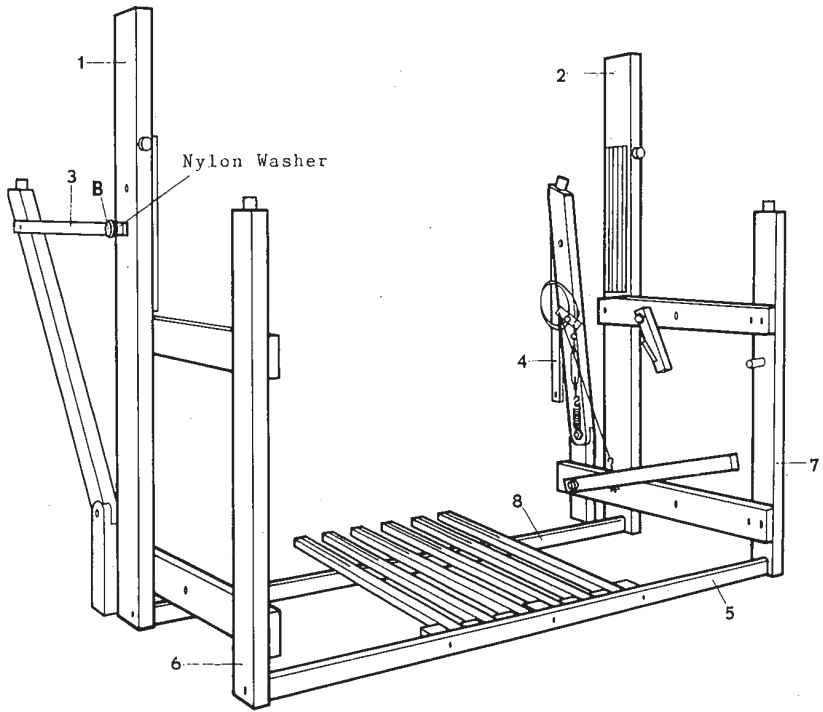

FIGURE 1

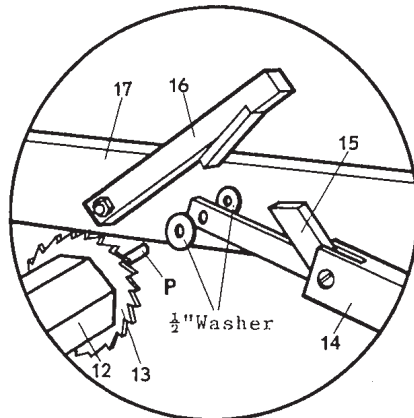

FIGURE 2

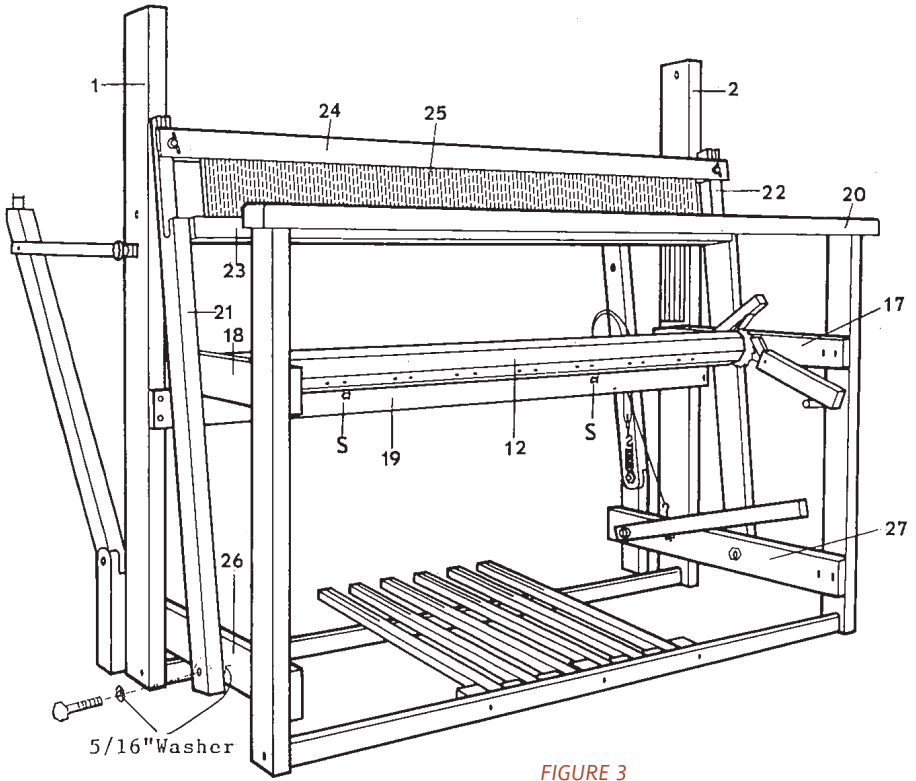

FIGURE 3

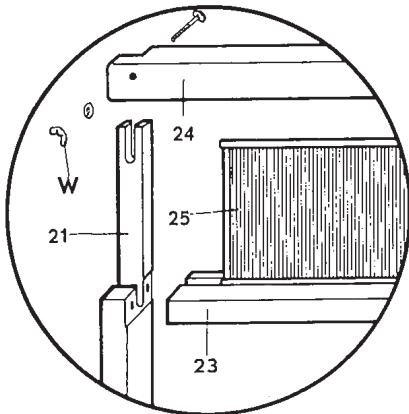

FIGURE 4

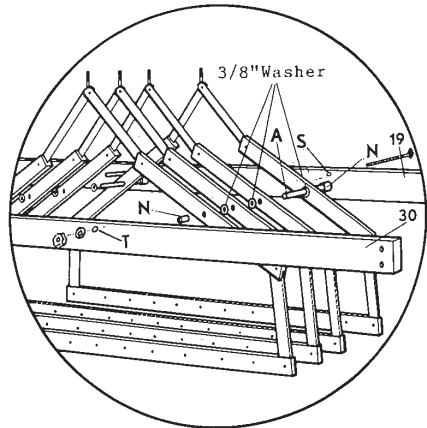

FIGURE 5

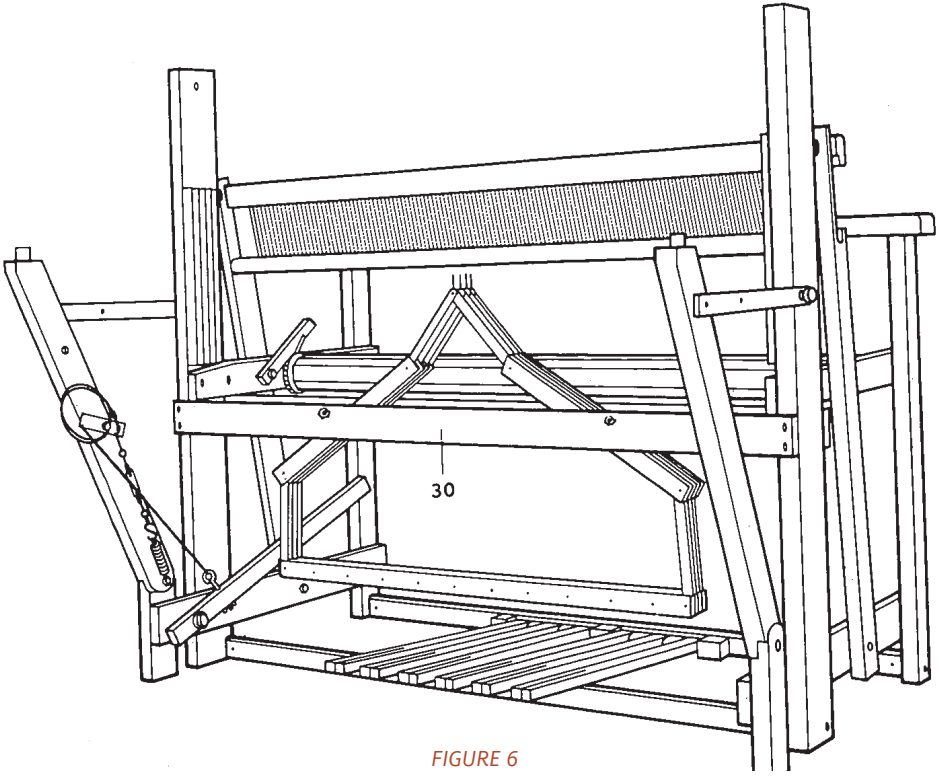

FIGURE 6

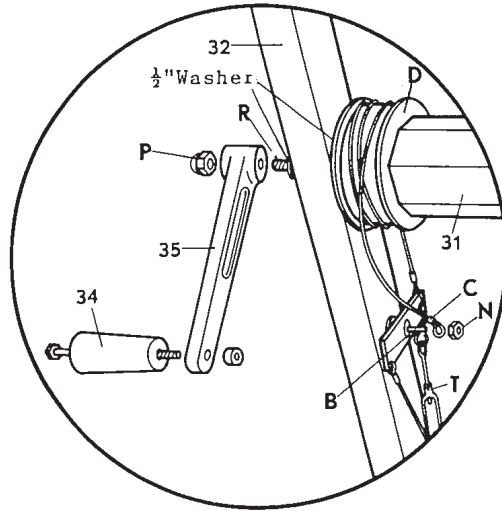

FIGURE 7

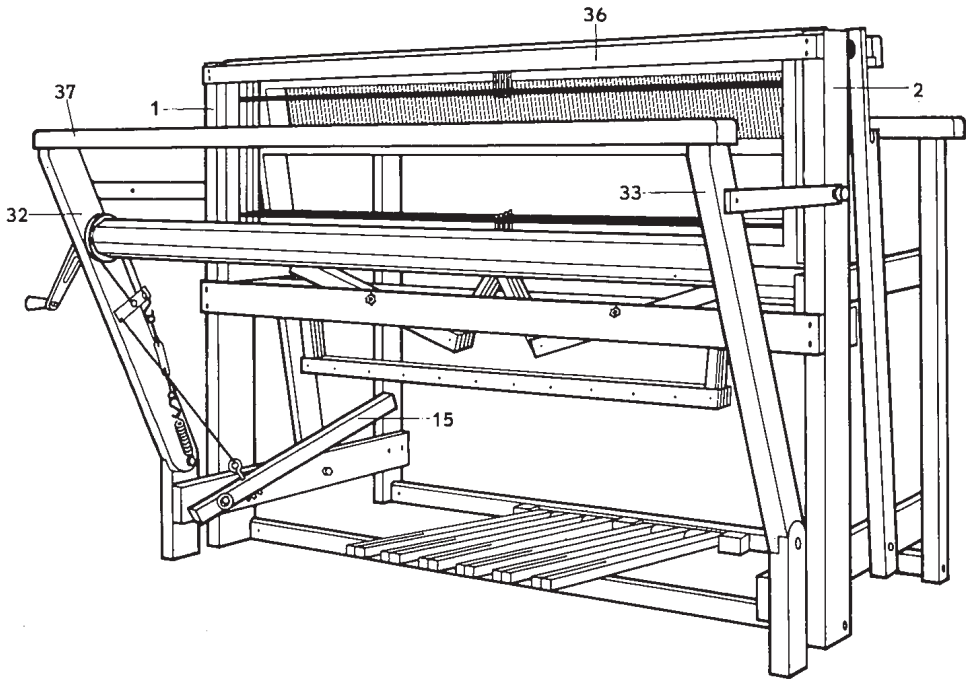

FIGURE 8

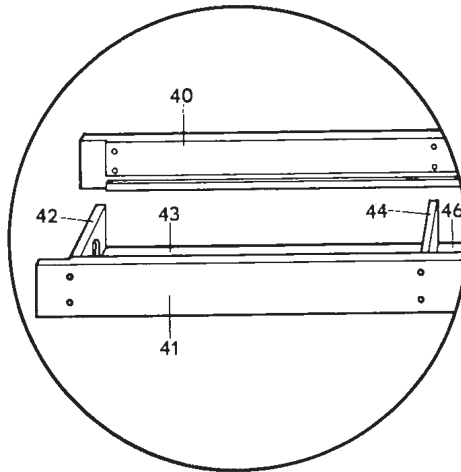

FIGURE 9

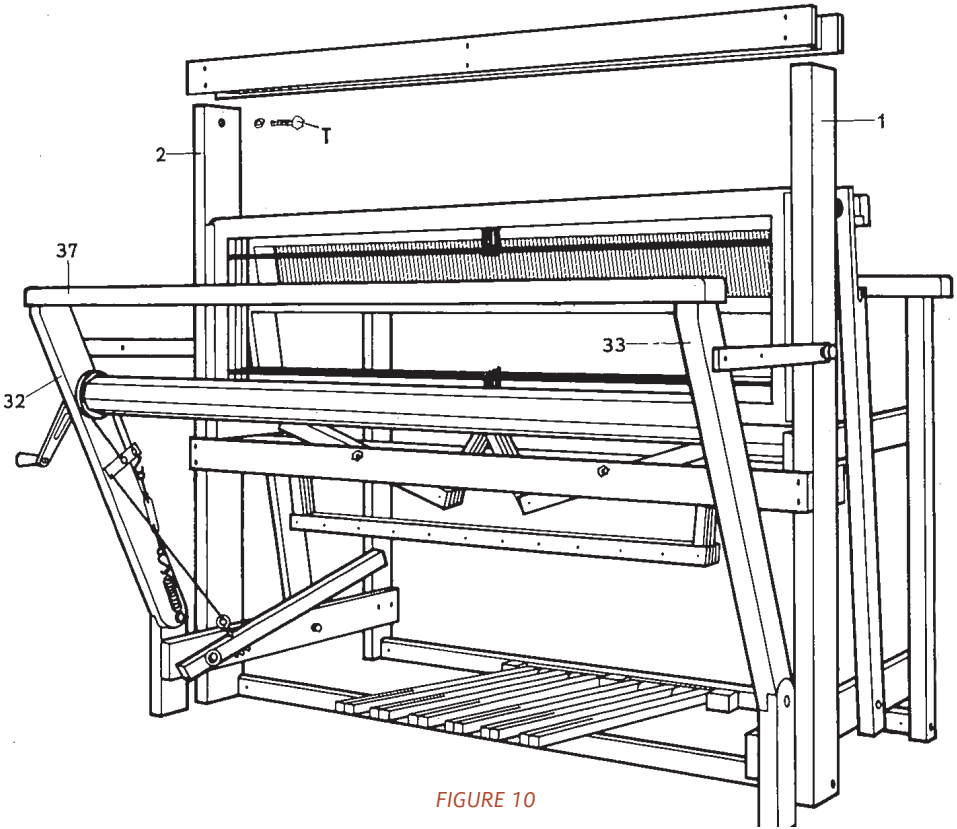

FIGURE 10

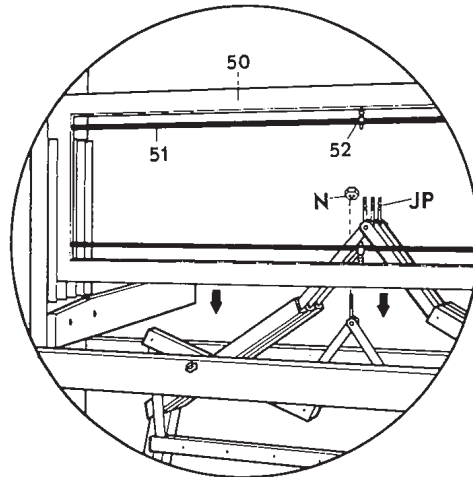

FIGURE 11

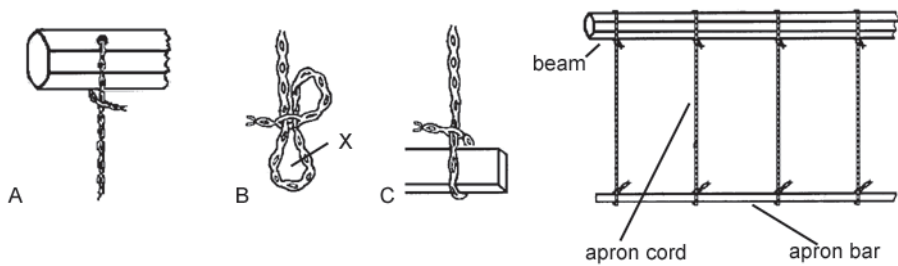

FIGURE 12

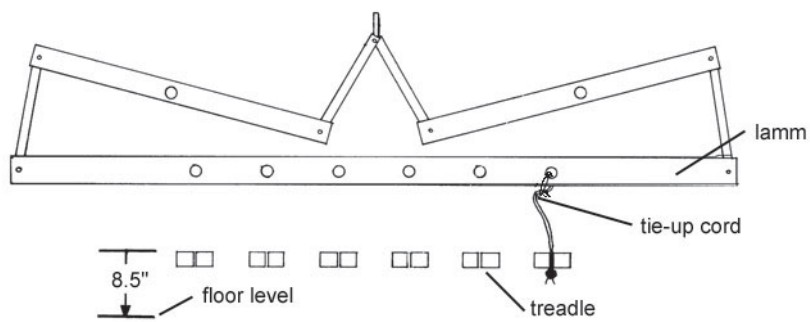

FIGURE 13