

# TABLE LOOM

## ASSEMBLY INSTRUCTIONS



Find out more at [schachtspindle.com](http://schachtspindle.com)  
Schacht Spindle Company 6101 Ben Place Boulder, CO 80301  
p. 303.442.3212 800.228.2553 f. 303.447.9273

## PARTS

- 1 - Base assembly
- 1 - Castle assembly
- 1 - Beater assembly
- 1 - Reed
- 2 - Castle braces
- 2 - Lease sticks
- 3 - Apron bars

Heddle bar hooks (for 25" looms only)

8 for 4-Shaft (4S) or 16 for 8-Shaft (8S)

Heddle bars: 8 for 4-Shaft or 16 for 8-Shaft

Heddles:

4-Shaft: 15" & 20" - 300; 25" - 400

8-Shaft: 15" - 300; 20" - 400; 25" - 500

4 - #8 x 1½" Trusshead screws (for 8S only)

4 - Rubber bumpers

2 - Barrel nuts

¼ x 1 " Trusshead machine screws (6 for 4S or 12 for 8S)

2 - ¼ x 3" Trusshead machine screws

Apron cords: 15" - 6; 20" - 8; 25" - 10

1. Unpack the table loom and remove all of the packing material and tape. Locate the small plastic bag which contains the hardware and the apron cords for your loom (see parts list).

2. On 8-shaft looms only, the cross brace is only partially secured for shipping purposes. Remove the screws (A) on each side and discard. Raise the cross brace up and screw into both A & B with the four 1½" trusshead screws.

3. Loosely secure the castle braces to the rear legs with 3" trusshead machine screws and barrel nuts. Place the castle upright between the sides of the loom frame and secure it, threading the 1" trusshead screws through each loom side into the inserts on the inside of the castle side (2 per side on the 4S, 4 on the 8S). Secure the castle brace to the castle side in the same manner (D) (1 screw per side on the 4S, and

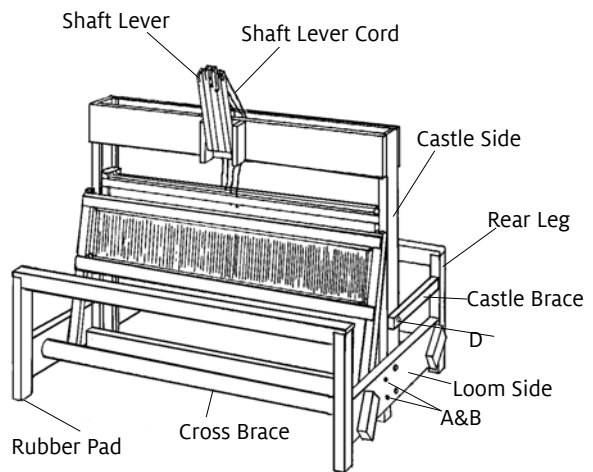

FIGURE 1: ASSEMBLED 4-SHAFT LOOM

2 on the 8S). Tighten the screw at the rear of the castle brace.

4. Peel the backing off the rubber bumpers and press them into the indentations in the bottom of the legs.
5. Attach the apron bars. Locate the pre-cut looped apron cords (one cord for each hole in the cloth and warp beams). Take one cord and insert one end a few inches through a hole in the beam. Now take the other end of the cord and put it through the second loop in from the short end that you put through the beam. Pull firmly on the cord to tighten it around the beam (see Fig. 2A). Repeat this procedure across each of the beams. To attach the apron bar to the apron cords, start at one end of the beam with the outermost cord and work across. Fold the end of the looped cord at about 4"

from the end and insert this doubled cord through the second loop from the end of the cord (see Fig. 2B). Slide the apron bar through the loop formed by the doubled over cord at point X. Pull the cord tight. Repeat across the entire beam.

6. Untie the shaft lever cords and remove the shafts from the bottom of the castle. Lay two heddle bars on a flat surface. Count out the heddles for the first shaft, and carefully transfer them in a single bunch from the holding bar or cord to the heddle bars. Place the heddle bars in the shaft. First fit one end of the heddle bar into the slot on one side of the shaft. Then bend the heddle bar slightly and fit the other end into the slot on the other side of the shaft. For 25" looms there are wire heddle bar hooks (2

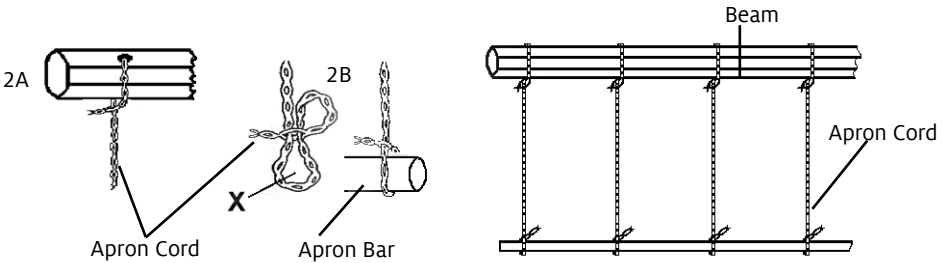

FIGURE 2: APRON CORDS

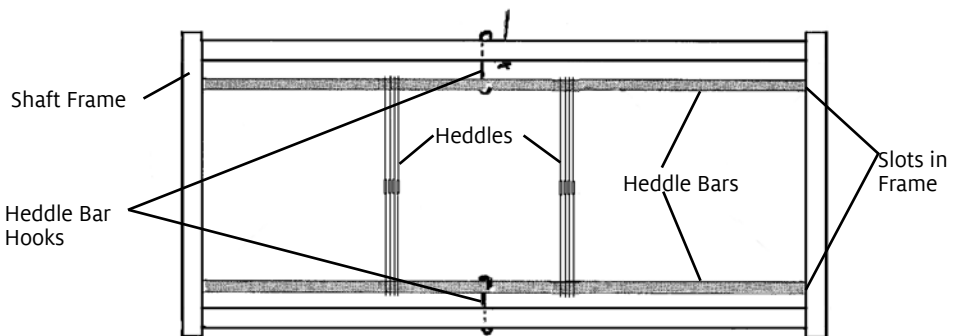

FIGURE 3: SHAFTS / HEDDLES

per shaft) to support the heddle bars. Slip the hooks through the holes near the center of the top and bottom shaft frame. Bend the heddle bar slightly to snap it into the hook.

7. Insert the shafts back into the castle from the bottom of the castle. Put the shaft levers in the up position. Attach the shaft lever cords to the levers (see Figure 4). Note: you can determine which lever you want tied up to the first shaft (i.e. the right side or the left side) at this time. On 4 shaft looms the cords from the first and second shafts go over the front small dowel in the top of the castle behind the levers. The cords from the third and fourth shafts go over the rear small dowel. Similarly on 8 shaft looms the first and second cords go over the front dowel, the third and fourth go over the second dowel, the fifth and sixth go over the third dowel, and the seventh and eighth go over the rear dowel. Adjust the shafts to a height of  $5\frac{1}{4}$ " below the top of the castle. This measurement is from the top of the harness side to the top of the castle (see Figure 5).

**Note: The correct position for an active lever is pointing toward you. If you pull the lever down too far it will interfere with the operation of the beater.**

8. Place the beater assembly onto the bolts that are screwed to the inside of the loom base. The wing nuts on the beater should be facing forward. To insert the reed into the beater, loosen the two wing nuts and raise the top of the beater, place the reed centered in the slot, slide the top of the beater down and secure the wingnuts. ■

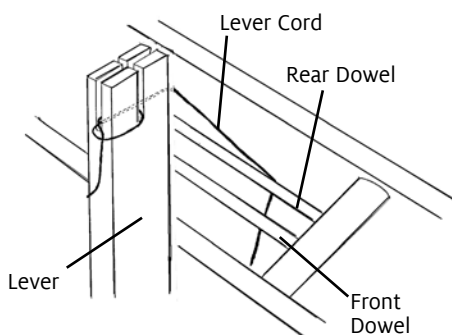

FIGURE 4: LEVERS

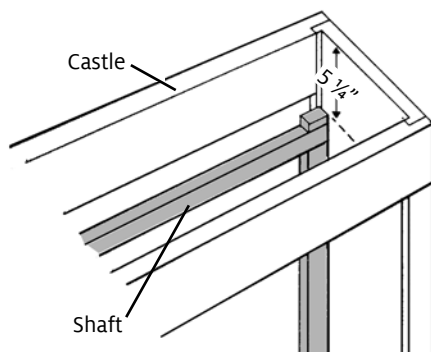

FIGURE 5: SHAFTS/CASTLE