

# LOOM BENCH

## ASSEMBLY INSTRUCTIONS



Loom Bench Shown with Optional Bench Bags



Find out more at [schachtspindle.com](http://schachtspindle.com)  
Schacht Spindle Company 6101 Ben Place Boulder, CO 80301  
p. 303.442.3212 f. 303.447.9273

© 2011 Schacht Spindle Company, Inc.

04.11

# LOOM BENCH

## ASSEMBLY INSTRUCTIONS

### HARDWARE

- 4 - 3-1/4" x 1/4" carriage bolts
- 8 - 1/4" flat washers
- 4 - 1/4" lock washers
- 4 - 1/4" hex nuts
- 4 - 2" x 1/4" truss head machine screws
- 8 - 1/4" barrel nuts
- 2 - 5/16" x 6-1/2" hex bolts
- 2 - 5/16" hex nuts
- 10 - 1-3/4" phillips flat head tapping screws (there are two extra screws)
- 4 - 3-1/2" x 1/4" truss head machine screws

### REQUIRED TOOLS

- 1/2" wrench
- 7/16" wrench
- Phillips screwdriver
- Flat screwdriver
- Hammer or mallet

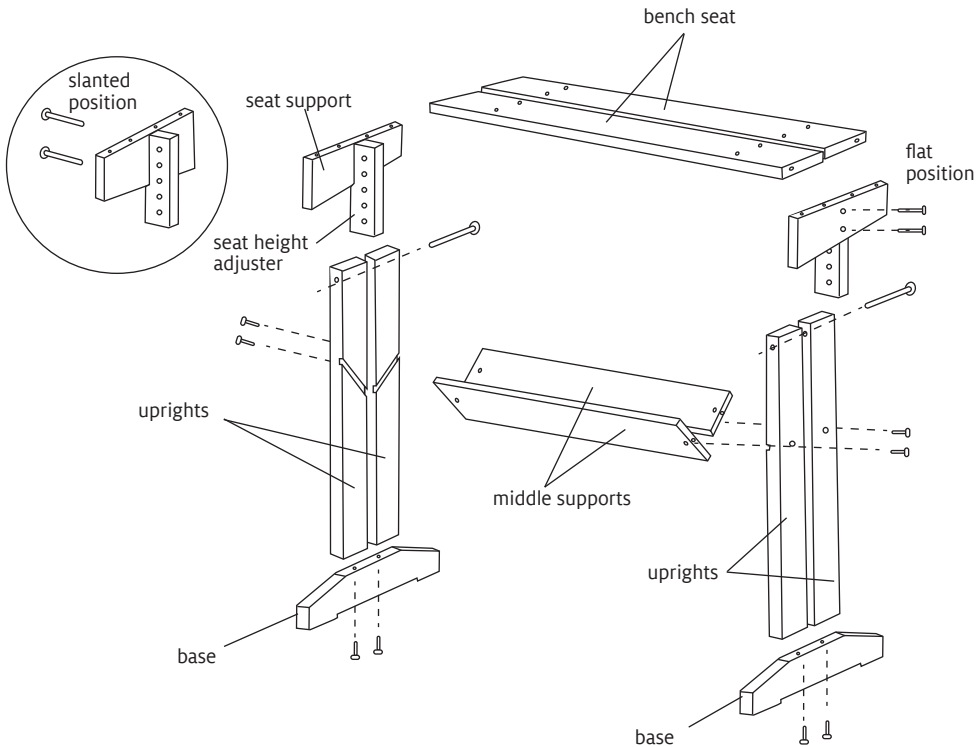

## ASSEMBLY

1. Before assembling the bench, decide whether you want your bench seat in a slanted or flat position. For a slanted seat position, assemble the bench seat supports to the seat height adjusters with the slanted part on top. For a flat seat position, follow the same instructions, but with the flat position on top.
2. Attach each seat support to the outside of each seat height adjuster with two 3-1/4" carriage bolts. Insert the bolts from the outside to the inside and tap the head of the carriage bolt into the wood with a hammer. Place a flat washer, lock washer and 1/4" hex nut on each bolt and tighten.
3. Assemble each base to an upright using two 3-1/2" truss head machine screws and two barrel nuts. Make sure the grooves in the uprights face the inside of the bench and the grooves meet to form a "V".
4. Assemble the middle supports to the uprights by placing them in the grooves and securing them with the 2" truss head machine screws and barrel nuts.
5. Fit the seat height adjusters between the uprights. For a bench 20" high, line up the holes in the top of the uprights with the top holes in the seat height adjusters. Slip a 5/6" x 6-1/2" hex bolt with a flat washer through the holes. Put another flat washer on the end and thread on a 5/16" hex nut. Arrange the seat height adjuster so that it is vertical and tighten the hex bolts.
6. Place the bench seats on top of the bench seat supports. Be sure that the countersunk holes are facing up, and the rounded corners are on the outside. Line up the holes in the seat with the pre-drilled guide holes in the bench seat supports. If needed, readjust the seat height adjusters so the holes in the bench seat and the holes in the bench seat supports line up. Screw the bench seat down with 8 of the 1 3/4" flat head screws.
7. Your bench is now assembled with a height of 20". Test this height with your loom. If you want the bench to be higher, pull out the hex bolts from the top of the uprights, raise the seat to the height you want and slip the hex bolts back through the holes and tighten them. The maximum bench height is 24". ■

# BENCH BAG

## ASSEMBLY INSTRUCTIONS

### PARTS

- 2 – steel rods
- 1 – wood bench bag end
- 1 – cloth bag

### TOOLS

- Hammer or mallet
- Scrap wood

1. Rub a little bar soap along 1" of each end of the steel rods.
2. Gently tap the steel rods into the holes in the ends of your Schacht bench seat. Place a scrap of wood between the hammer and the steel rods to protect the ends of the rods.
3. Slip the bench bag onto the rods.
4. Line up the holes in the wood bench bag end with the steel rods. Use the scrap wood as protection between your hammer and the wood bench bag end.

